

Mobilné systémy 3. generácie

UMTS

Ing. Matúš Turcsány, PhD.

turcsany@ktl.elf.stuba.sk

KTL FEI STU
2010



Prehľad prednášok

- UMTS
- HSDPA, EUL
- HSPA evolution
- LTE
- LTE-Advanced

Mobile subscriptions market share worldwide



www.gsa.com.com

Mobile subs market share per technology Q2 09

CDMA 9.8%

Other 0.7%

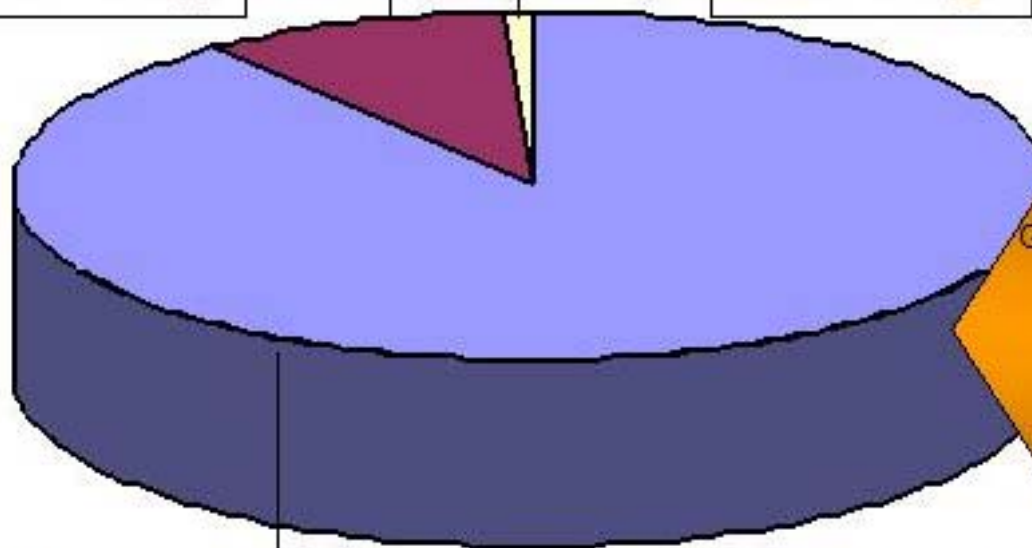

GSM/WCDMA 89.5%

Total subs: all mobile technologies Q2 09 = 4.312 billion

GSM subs including WCDMA – HSPA

>3.85 billion

Of which 378 million are WCDMA (including HSPA)

*Others = AMPS, iDEN, NMT, FDC, TD-SCDMA, US TDMA

GSA – Global mobile Suppliers Association

Data Source
informa
telecoms & media

□ GSM inc WCDMA subs market share grew 1.6% YoY

□ GSM/WCDMA market share Q2 08 was 87.9%

Mobile subscriptions market share worldwide

☐ Total mobile market = > 4.96 billion subscriptions: Q2 10



www.gsacom.com

Mobile market share worldwide Q2 2010

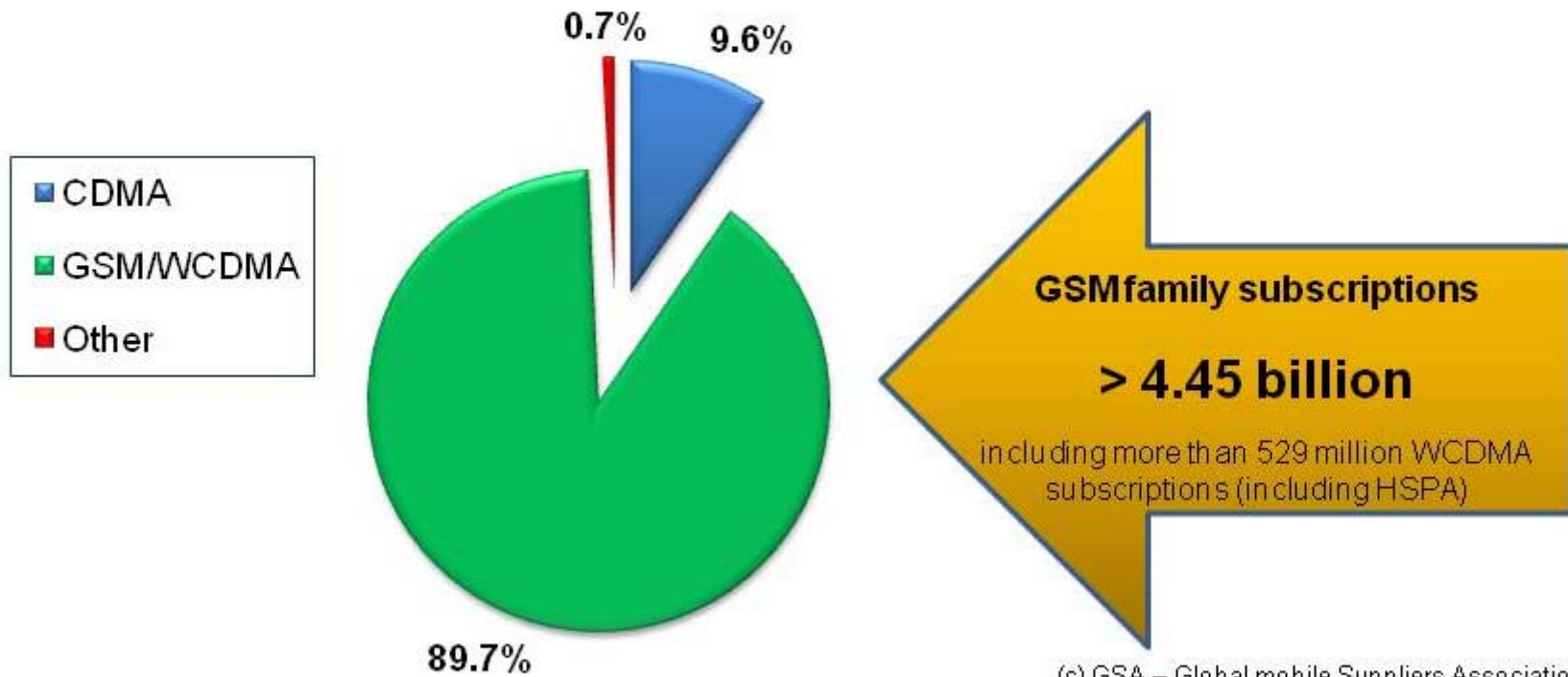

(c) GSA – Global mobile Suppliers Association

☐ GSM/WCDMA market share Q2 09 was 89.3%

3G subscriptions growth worldwide



www.gsacom.com

WCDMA (inc HSPA) has 76% market share of 595.7 million 3G subscriptions globally

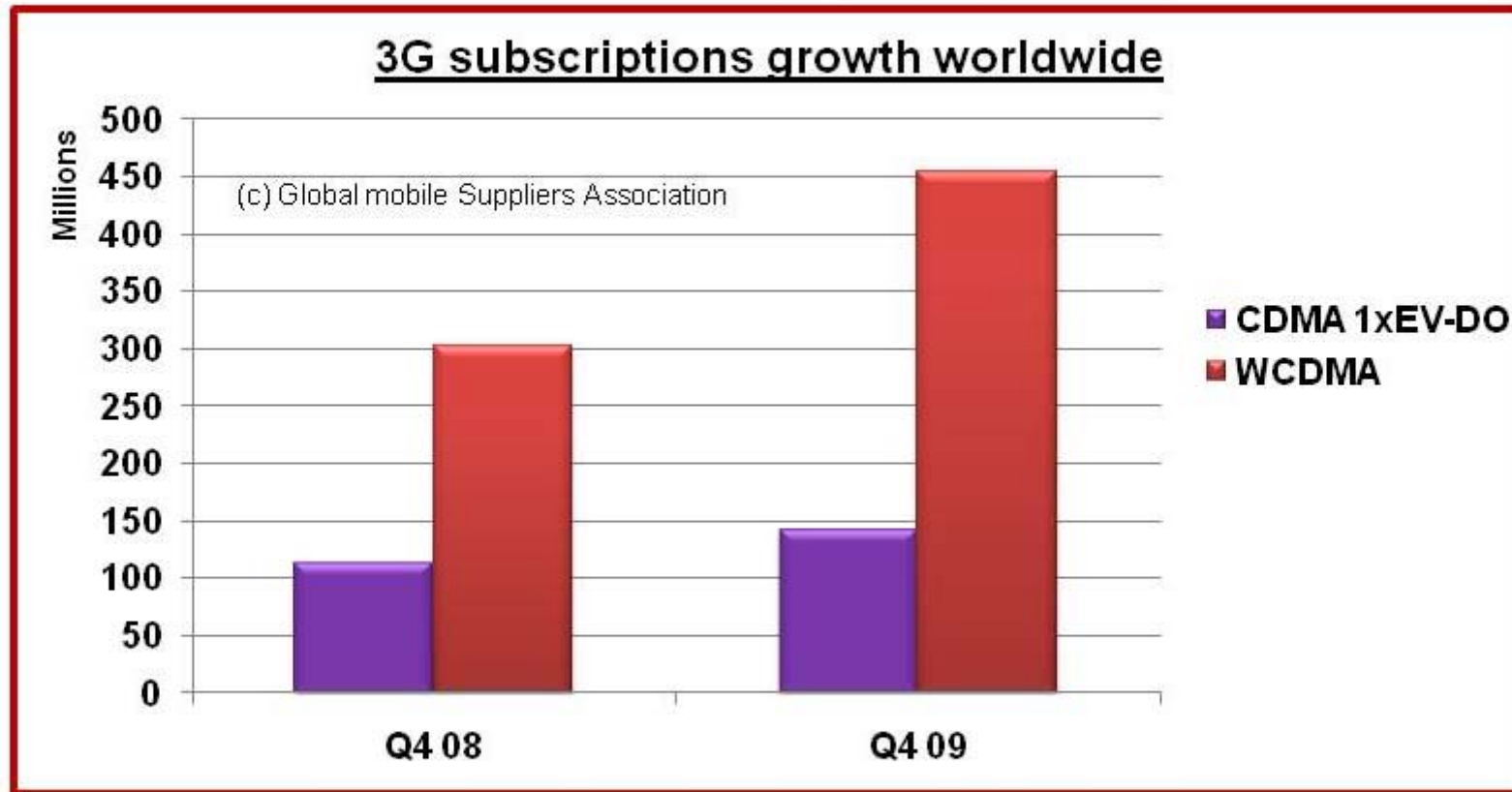

WCDMA (inc HSPA) growth YoY = 50%

WCDMA-HSPA subs: Informa Telecoms and Media
CDMA 1xEV-DO subs: CDG website

373 3G/WCDMA commercial operators

- ❑ WCDMA networks are commercially launched in 152 countries
- ❑ Excludes MVNOs; multi-band networks counted as single networks
- ❑ 370 WCDMA operators have launched HSPA in 151 countries

Over 99% of commercial WCDMA operators have launched HSPA !



www.gsacom.com

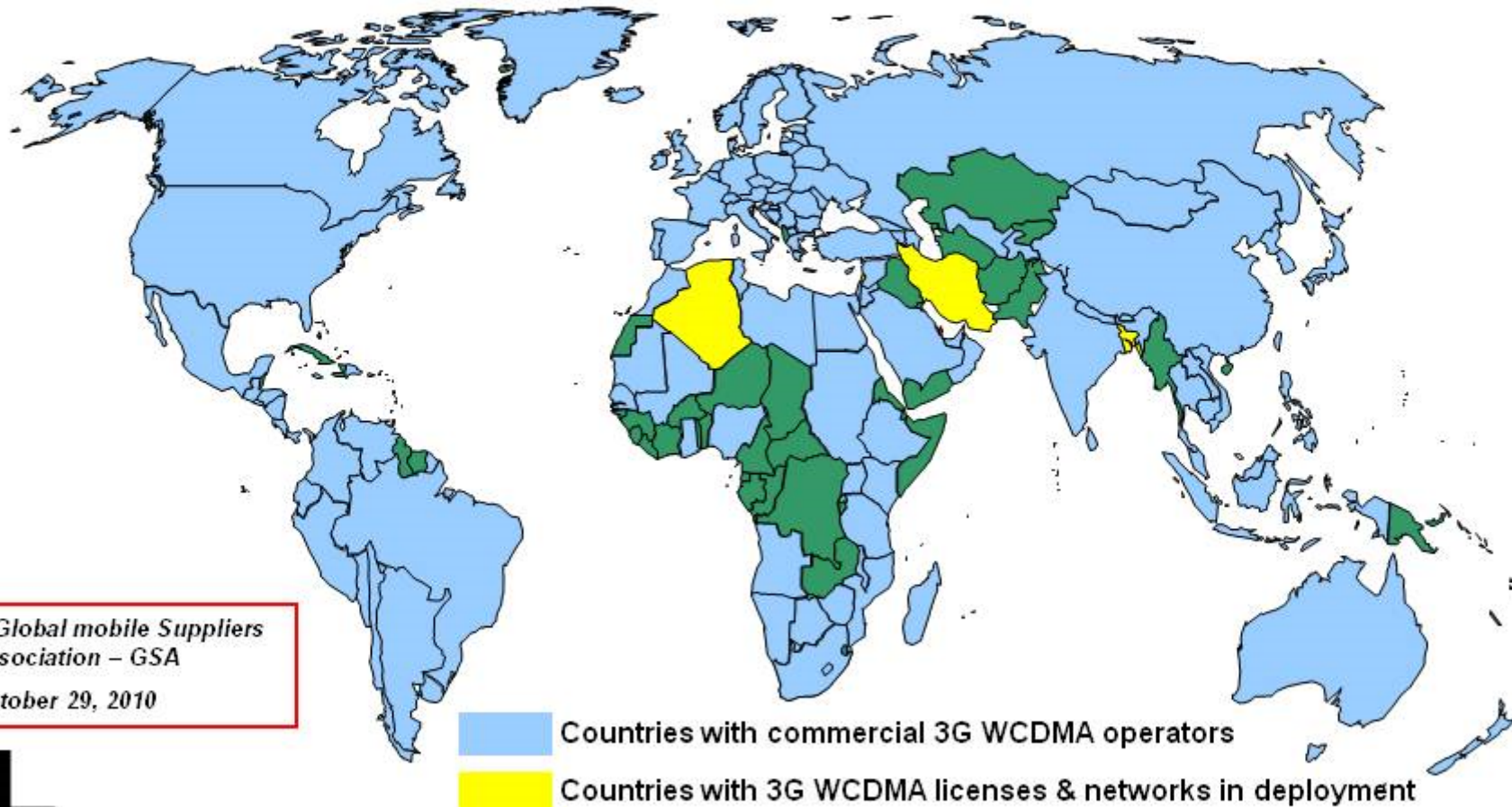

Evolúcia štandardov

3GPP



3GPP2

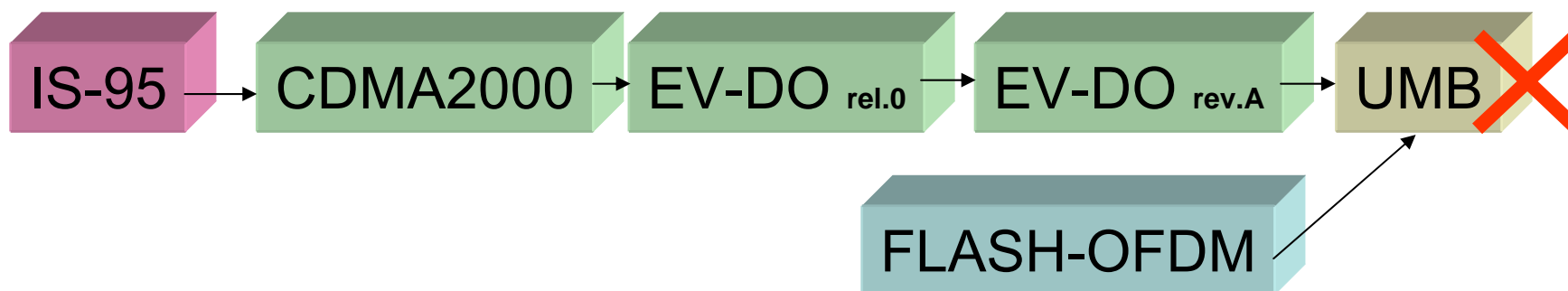

IEEE

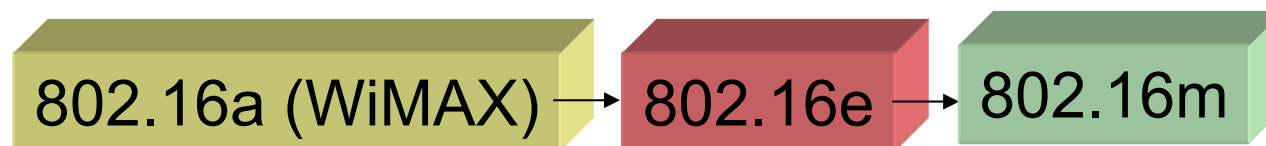

Evolúcia štandardov

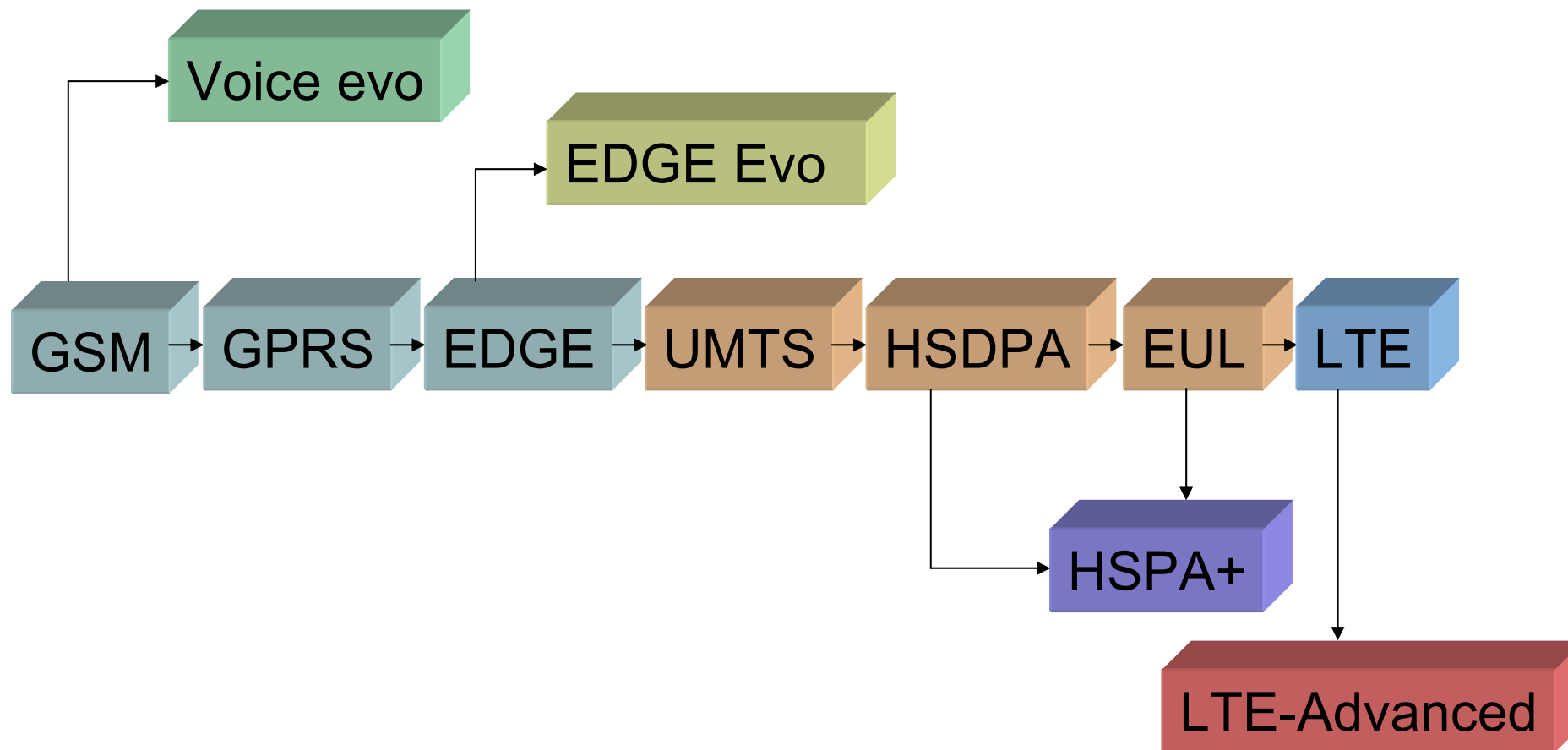

IMT-2000

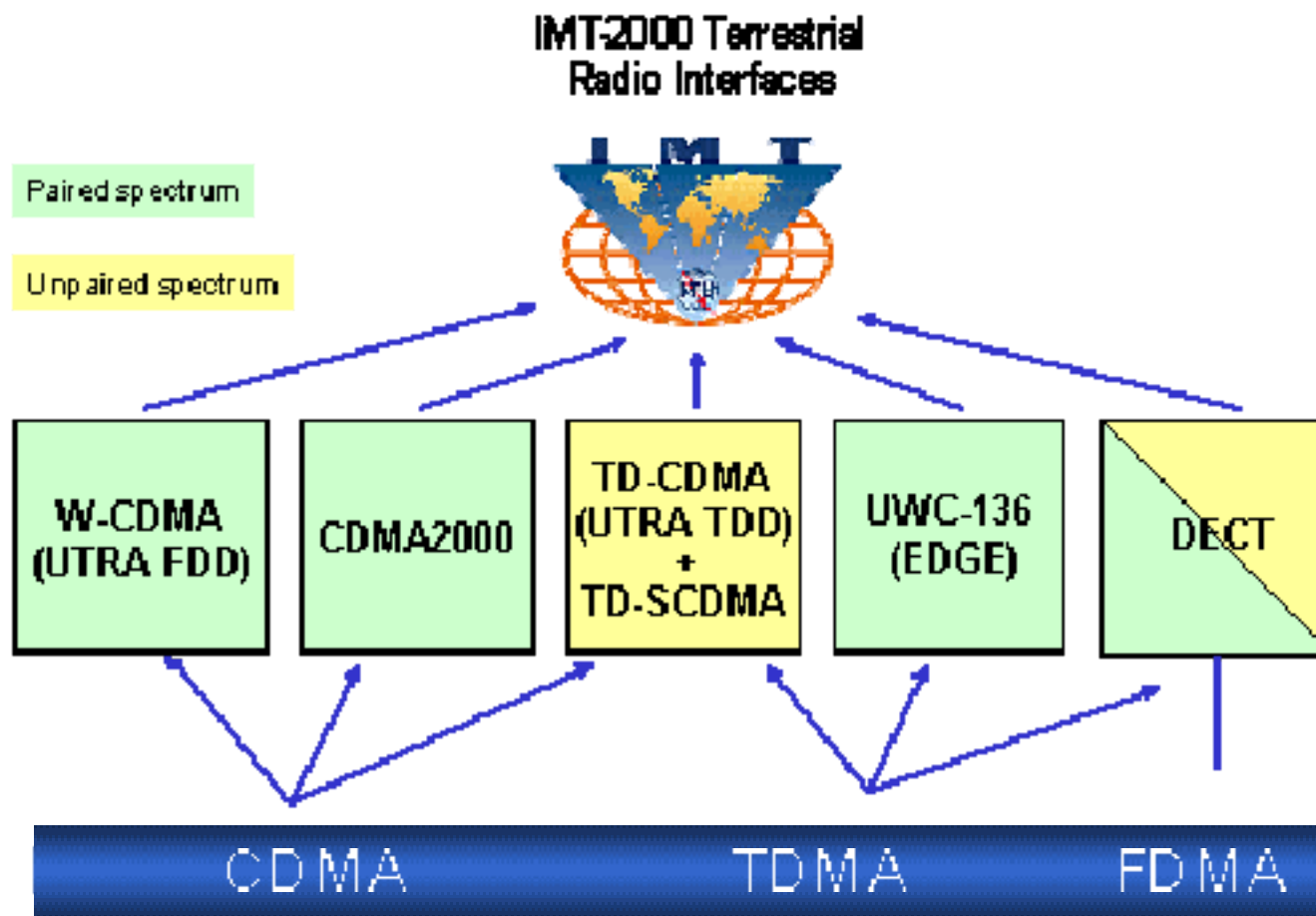

3GPP

TSG ORGANIZATION

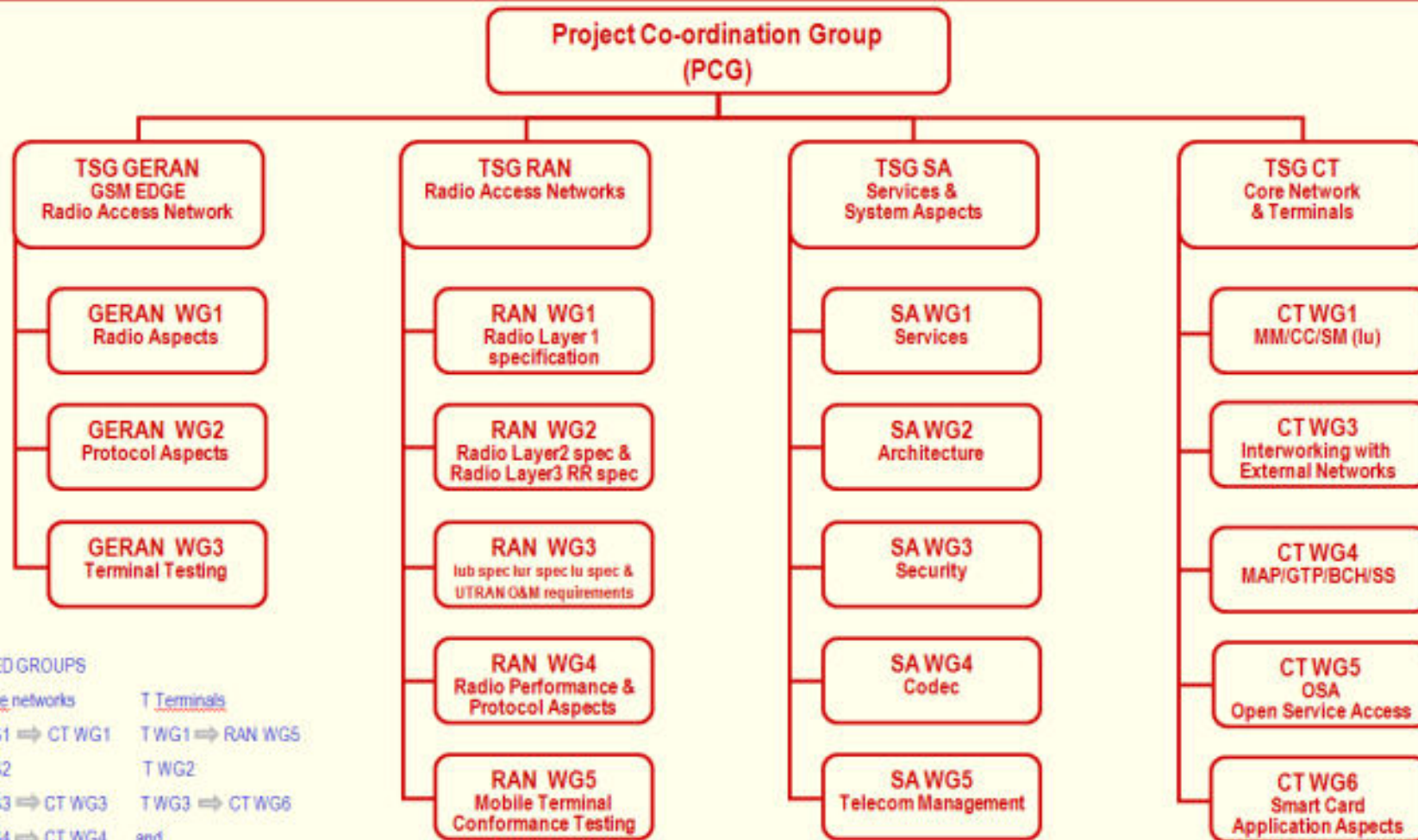

CLOSED GROUPS

CN Core networks

CN WG1 ⇒ CT WG1

CN WG2

CN WG3 ⇒ CT WG3

CN WG4 ⇒ CT WG4

CN WG5 ⇒ CT WG5

T Terminals

T WG1 ⇒ RAN WG5

T WG2

T WG3 ⇒ CT WG6

and

GERAN WG4 ⇒ GERAN3

GERAN WG5 ⇒ GERAN3

3GPP spec. list

Subject of specification series	3G/GSM R99 and later
Requirements	21 series
Service aspects ("stage 1")	22 series
Technical realization ("stage 2")	23 series
Signalling protocols ("stage 3") - user equipment to network	24 series
Radio aspects	25 series
CODECs	26 series
Data	27 series
Signalling protocols ("stage 3") -(RSS-CN)	28 series
Signalling protocols ("stage 3") - intra-fixed-network	29 series
Programme management	30 series
Subscriber Identity Module (SIM / USIM), IC Cards. Test specs.	31 series
OAM&P and Charging	32 series
Security aspects	33 series
UE and (U)SIM test specifications	34 series
Security algorithms (3)	35 series
Evolved UTRA aspects	36 series

Architektúra

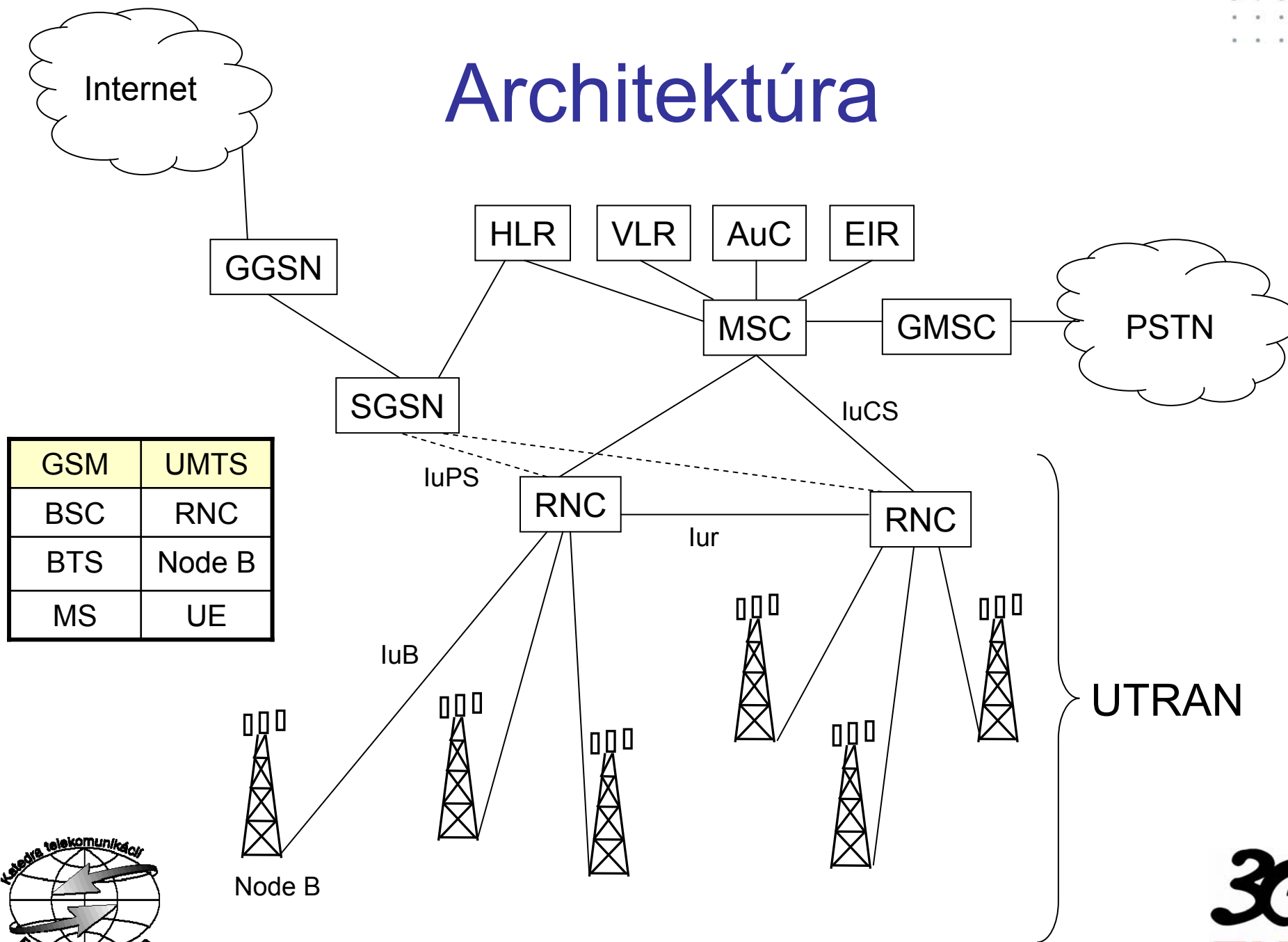

GSM	UMTS
BSC	RNC
BTS	Node B
MS	UE



UTRAN



Roadmap

3GPP releases

	Rel.99/4	Rel.5	Rel.6	Rel.7	Rel.8	Rel.9
	WCDMA	HSDPA	EUL	HSPA+	HSPA+	HSPA+
	QPSK	16QAM	multi code	MIMO, 64QAM, 16QAM UL	DC	Comb
DL Mbit/s	0.384	14.4	14	28	42	168
UL Mbit/s	0.384	0.384	5.8	12	12	24
Latency (ms)	~150	~75	~50	~30	~30	~30

↑
LTE

3G – voice or data?

Relative Network Load – RNC level

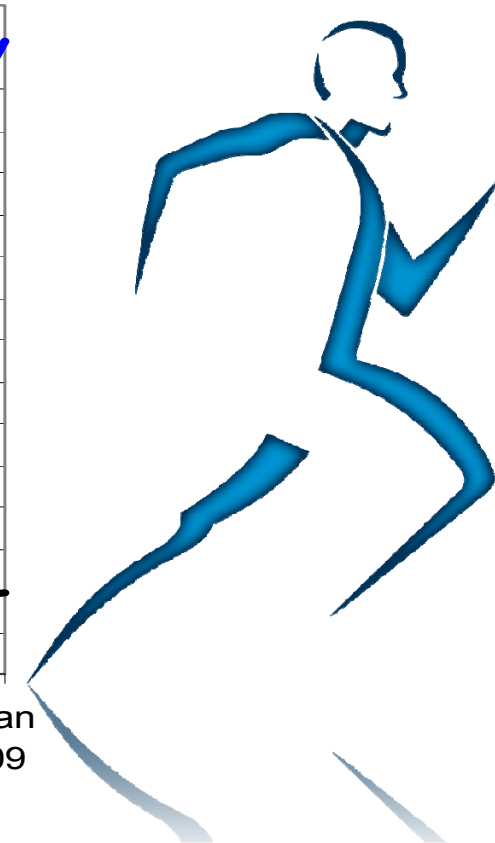
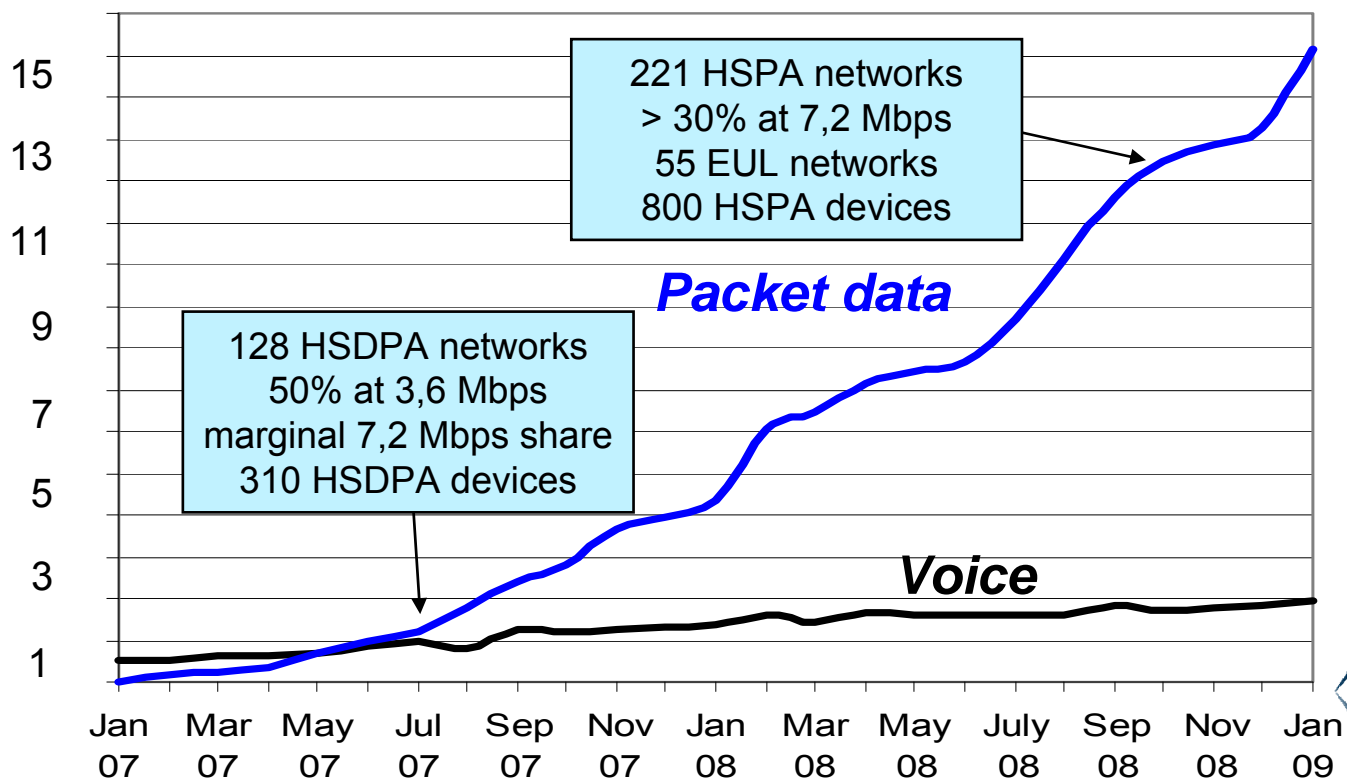

Data is surpassing voice on 3G since 2 years



Rádiová prístupová sieť- UTRAN

- Komponenty
 - Node B
 - RNC
- Multiplexná technika
 - CDMA
- Duplexný mód
 - FDD
 - TDD

Funkcie Node B

- Air interface Transmission / Reception
- Modulation / Demodulation
- CDMA Physical Channel coding
- Micro Diversity (Soft Handover)
- Error Handling
- Closed loop power control

Funkcie RNC

- Radio Resource Control
- Admission Control
- Channel Allocation
- Power Control Settings
- Handover Control
- Macro Diversity (Soft Handover)
- Ciphering
- Segmentation / Reassembly
- Broadcast Signaling
- Open Loop Power Control



Duplexný mód

- **Frequency division duplex**
 - + symetric traffic (e.g. voice)
 - + higher average power
=> less Node Bs
 - higher complexity (HW)
 - channel measurements must be reported

- **Time division duplex**
 - + asymeric traffic (data)
 - + channel measurements are precise
 - lower average power
 - strict synchronization needed
 - higher delays

FDD

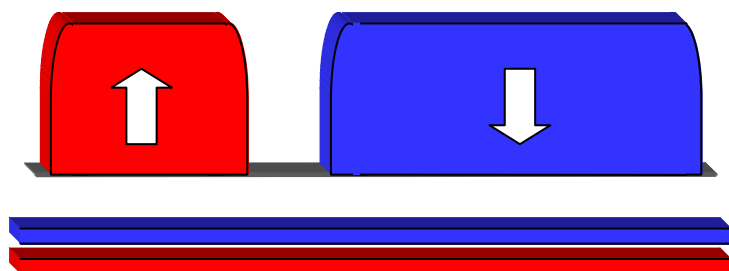

TDD

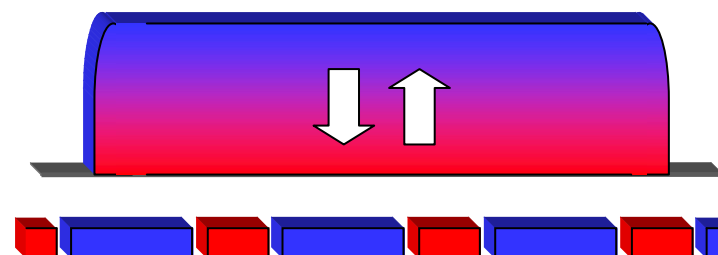

CDMA

- Interference limited system
 - Sequences selection is crucial
 - Power control needed
 - Soft handover possible
-
- 5 MHz channel
 - 3,84 Mchip/s



Soft handover

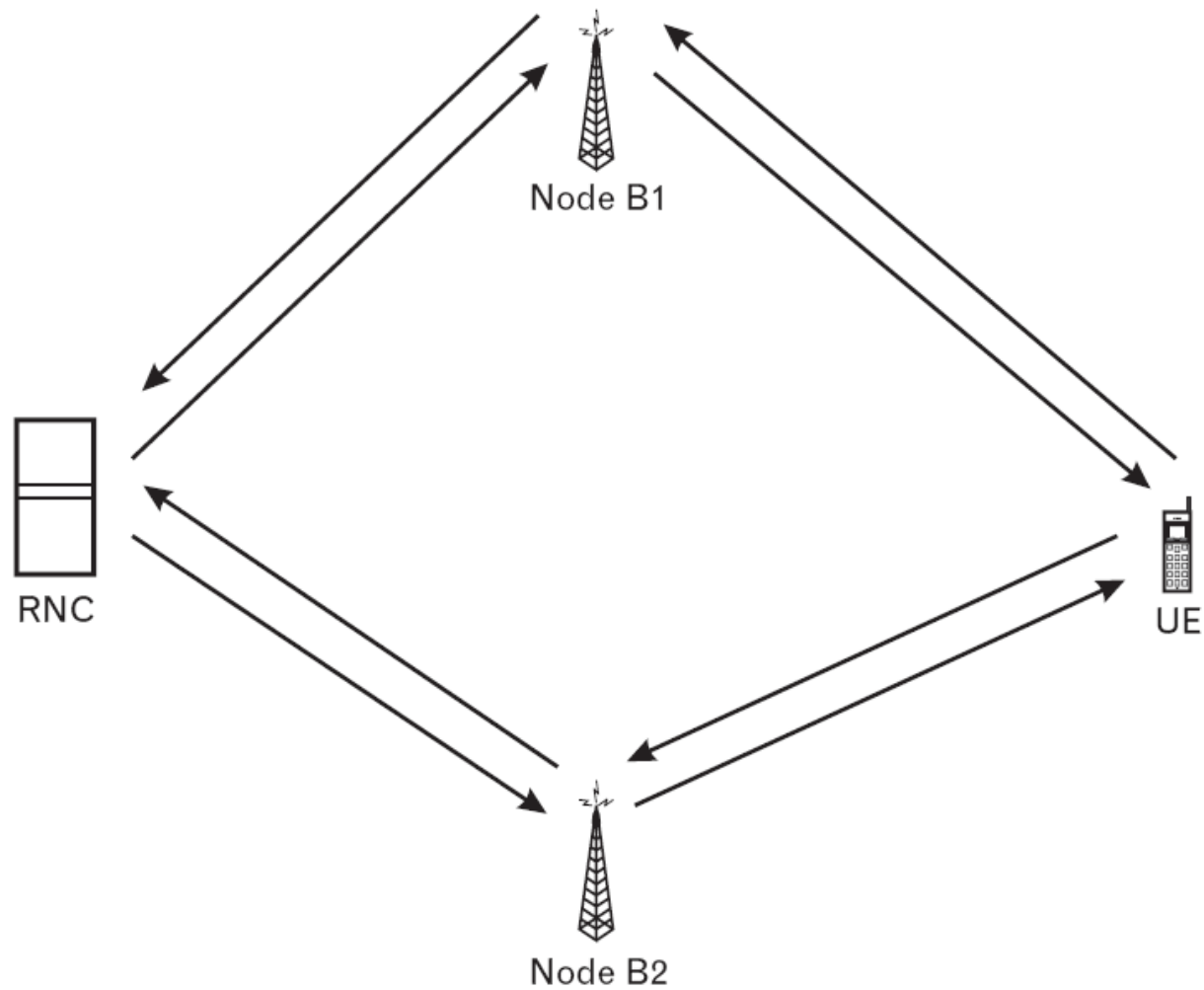

Importance of Soft Handover

- Graphs show probability of excessive interference in neighbouring cell
- Active set size of 4 was agreed as mandatory for UEs

1 user/cell, AS max = 1

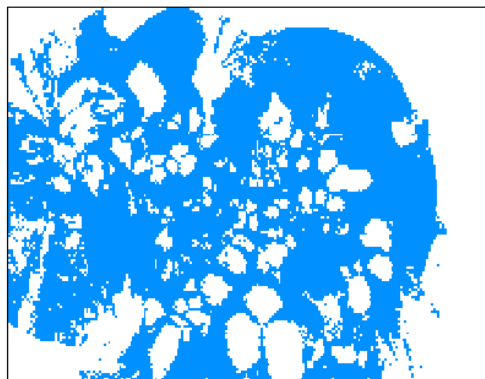

1 user/cell, AS max = 2

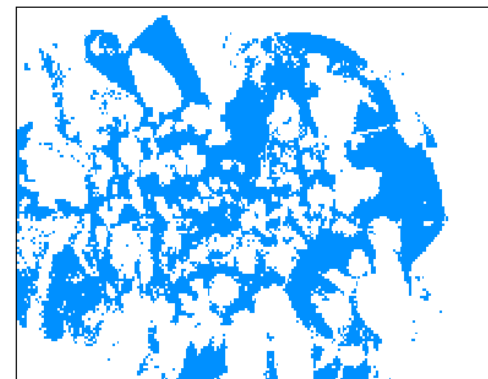

1 user/cell, AS max = 3

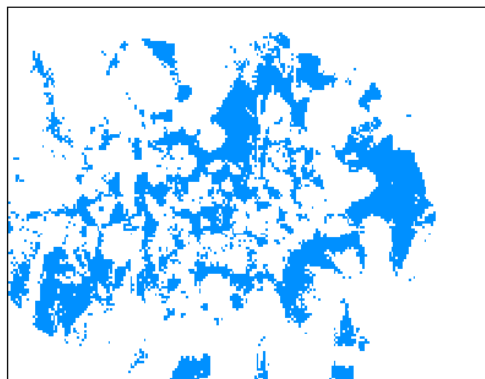

1 user/cell, AS max = 4

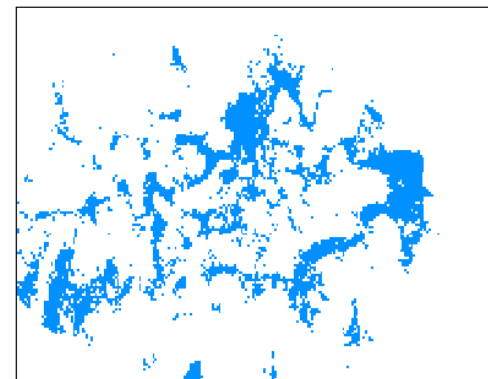

Why power control?

- NEAR – FAR effect
 - High interference between users & cell breathing

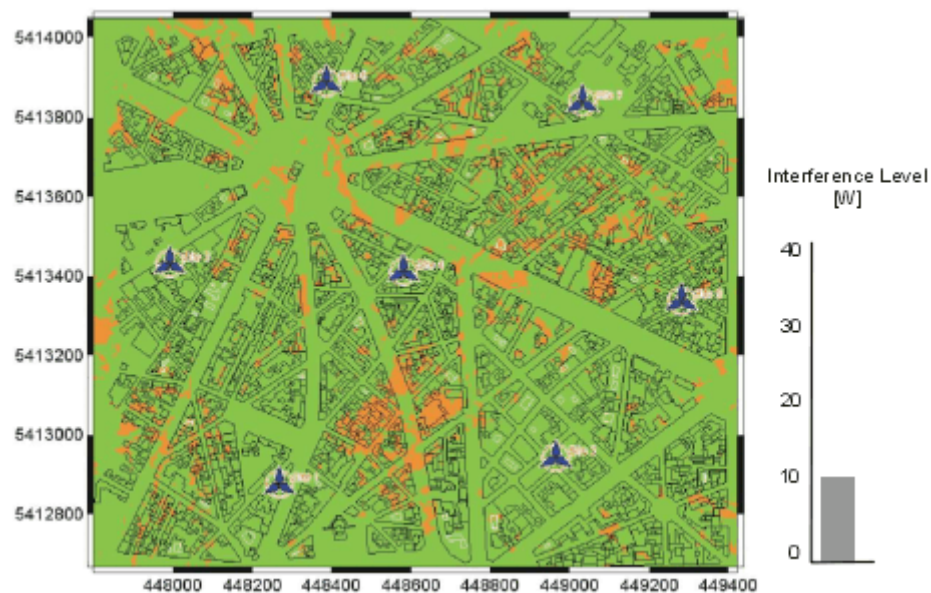

Power control

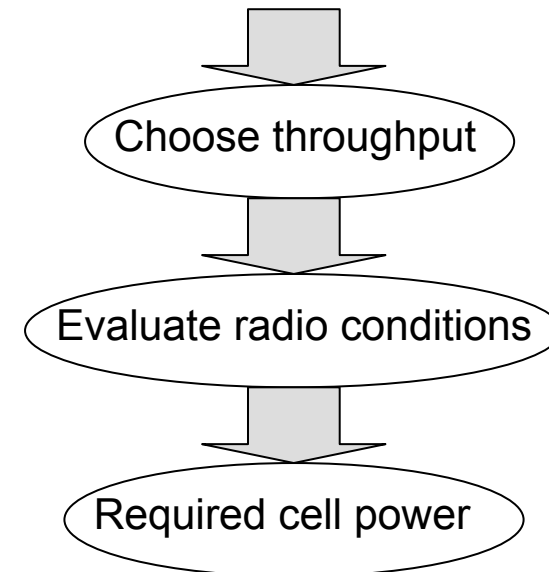
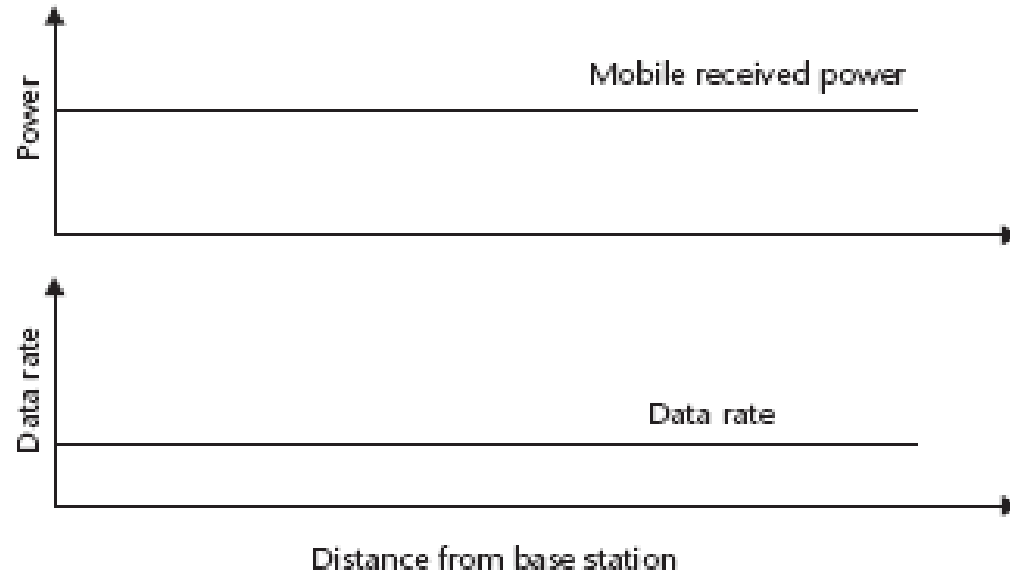

- Circuit switched services are guaranteed
- Packet switched services are best effort

Power control

- Open loop
 - initial access to the network

- Closed loop
 - INNER loop
 - Guarantee link quality (keep desired SIR)
 - 1500 times per second (Hz)

 - OUTER loop
 - Minimize transmit power by setting SIR target for inner loop
 - Estimate SIR target based on BLER

Air interface protocol model

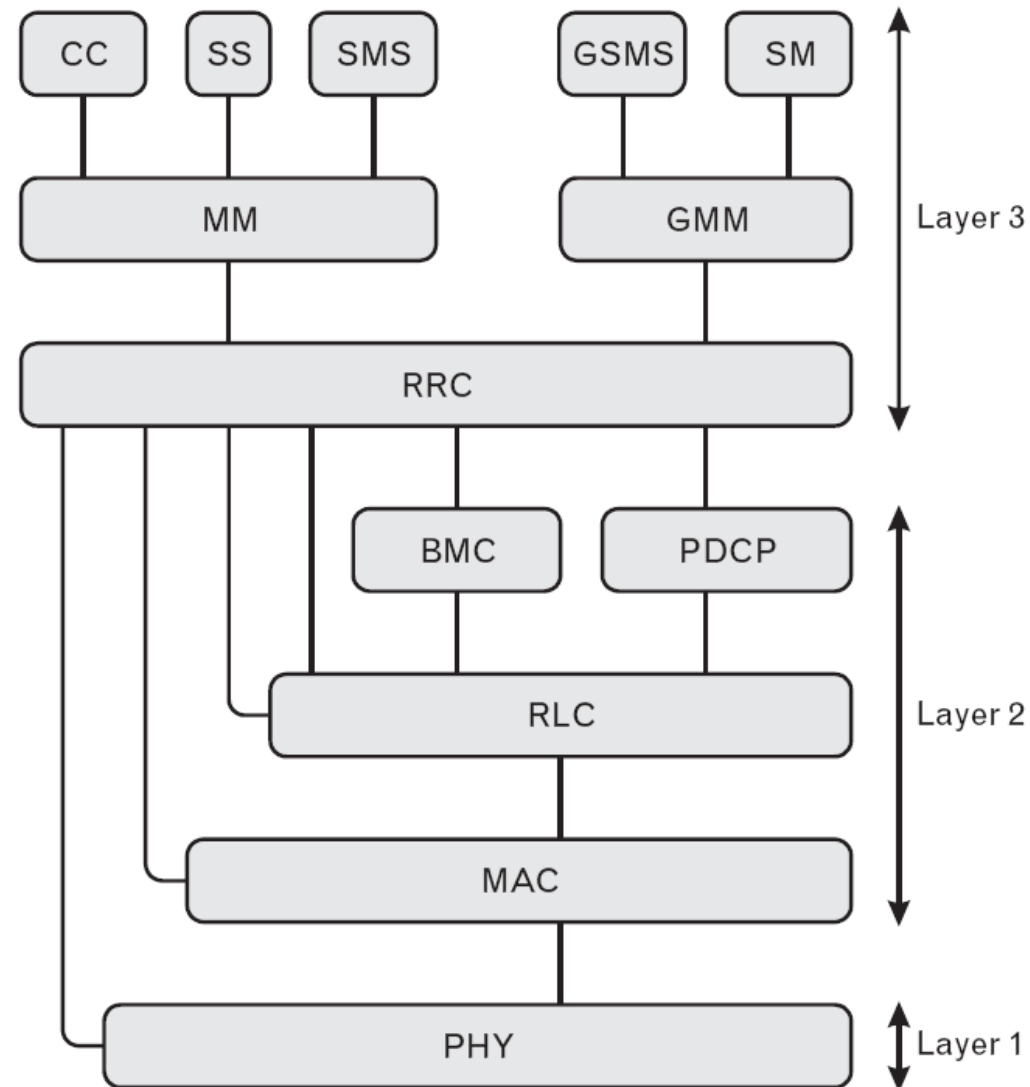

Channel concept

new for UMTS, not in GSM/GPRS

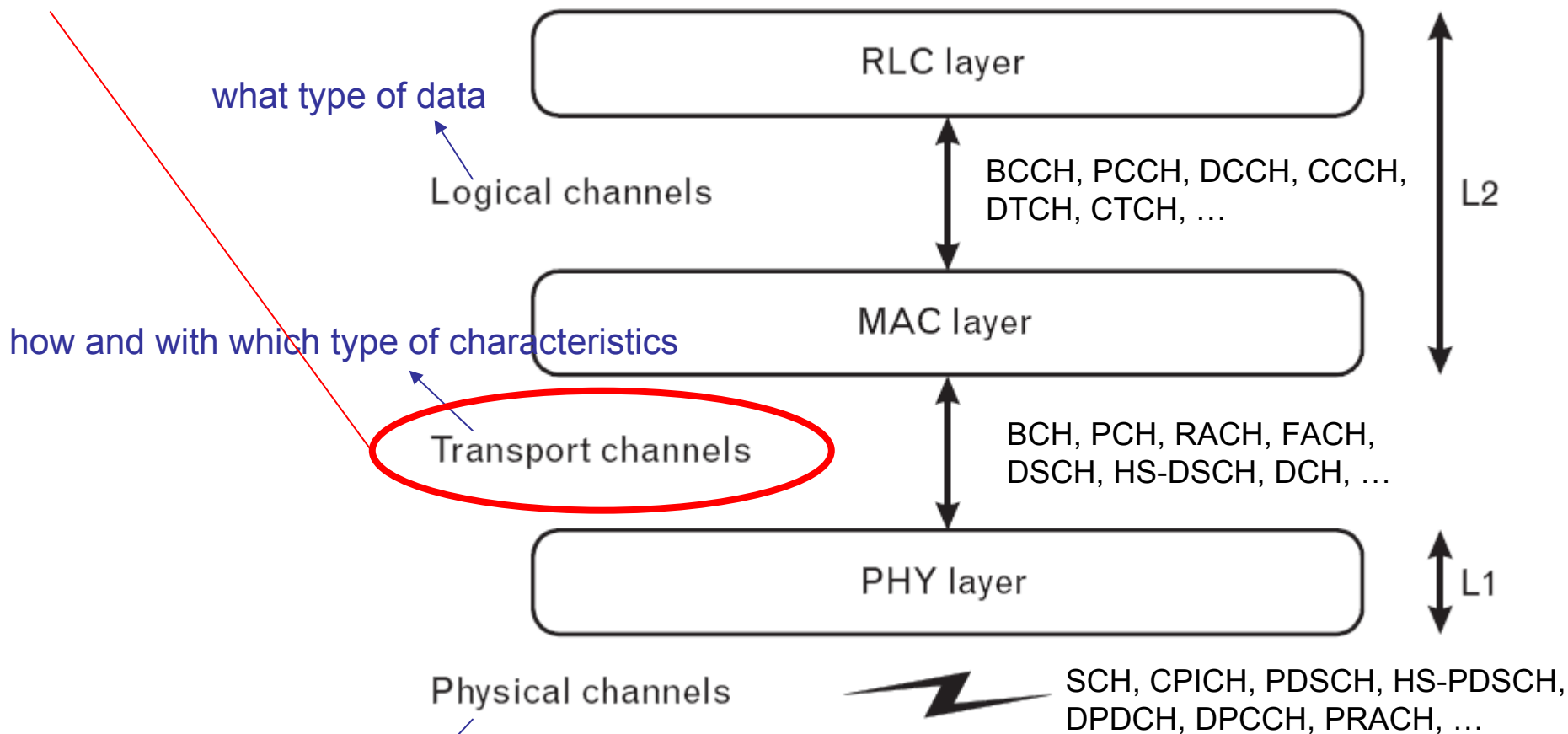

how and with which type of characteristics

Transport channels

define the exact physical characteristics

Logical channels

- Control channels
 - Common (P2M)
 - Dedicated (P2P)

- Traffic channels
 - Common
 - Dedicated

Transport channels

- Common channels
- Dedicated channel
 - DCH (UL & DL)

Physical channels

- Synchronization
- Pilot
- Paging
- Dedicated Physical Data Channel
- Dedicated Physical Control Channel
- High Speed Physical Downlink Shared Channel
- ...

Channels

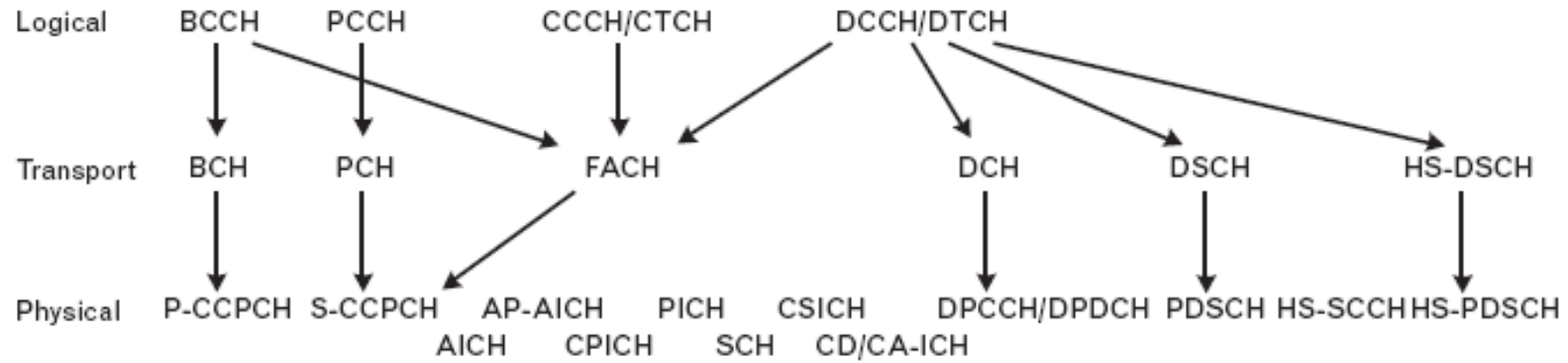

downlink

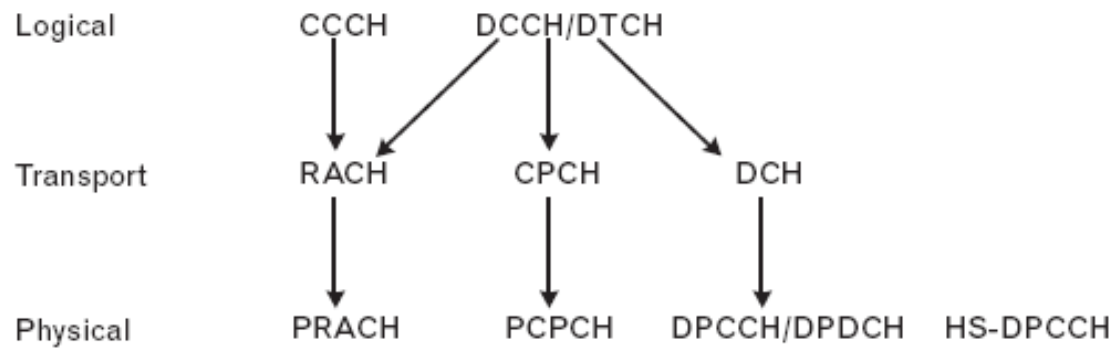

uplink

Channel structure - UL

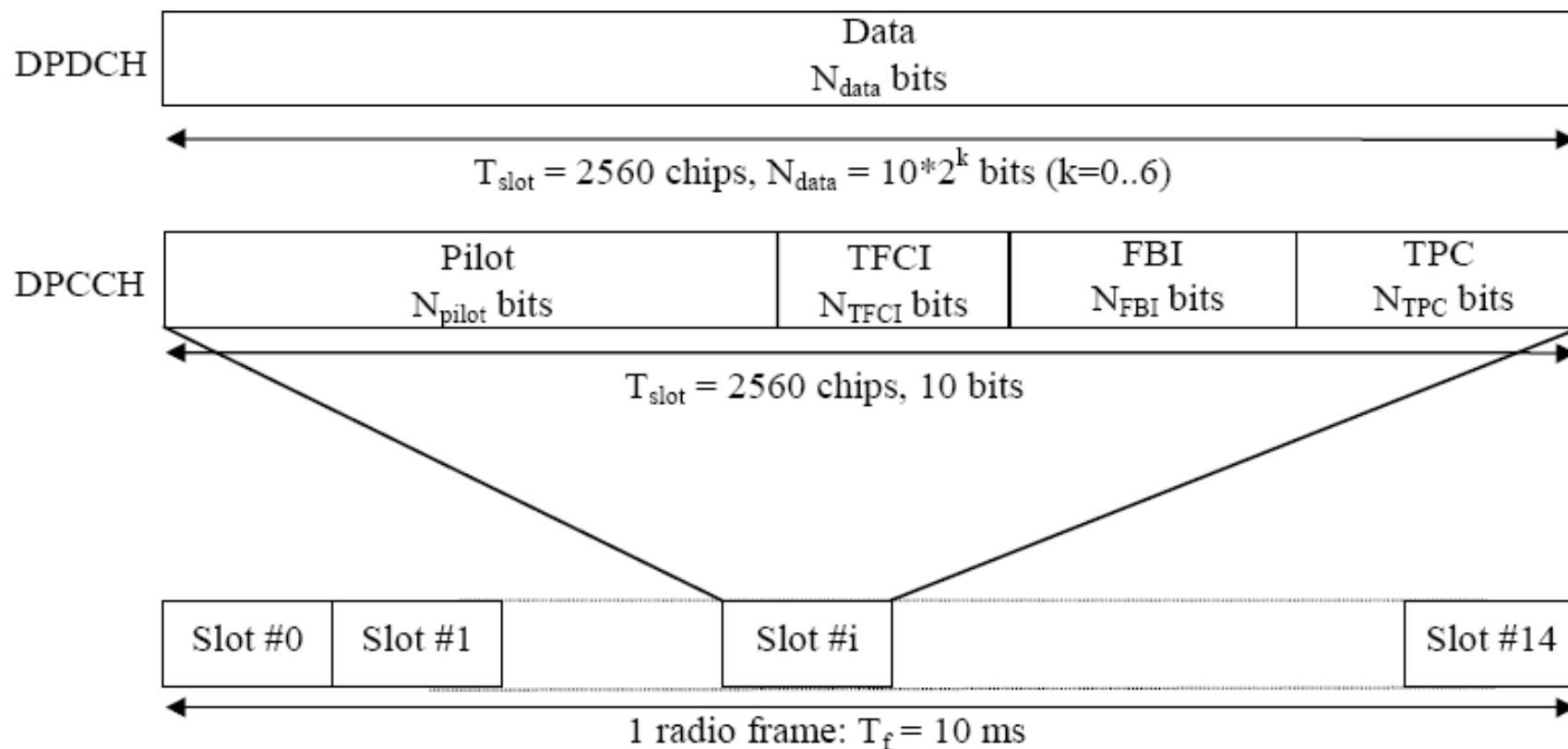

Channel structure - UL

Slot Format #i	Channel Bit Rate (kbps)	Channel Symbol Rate (ksps)	SF	Bits/ Frame	Bits/ Slot	N _{data}
0	15	15	256	150	10	10
1	30	30	128	300	20	20
2	60	60	64	600	40	40
3	120	120	32	1200	80	80
4	240	240	16	2400	160	160
5	480	480	8	4800	320	320
6	960	960	4	9600	640	640

Channel structure - DL

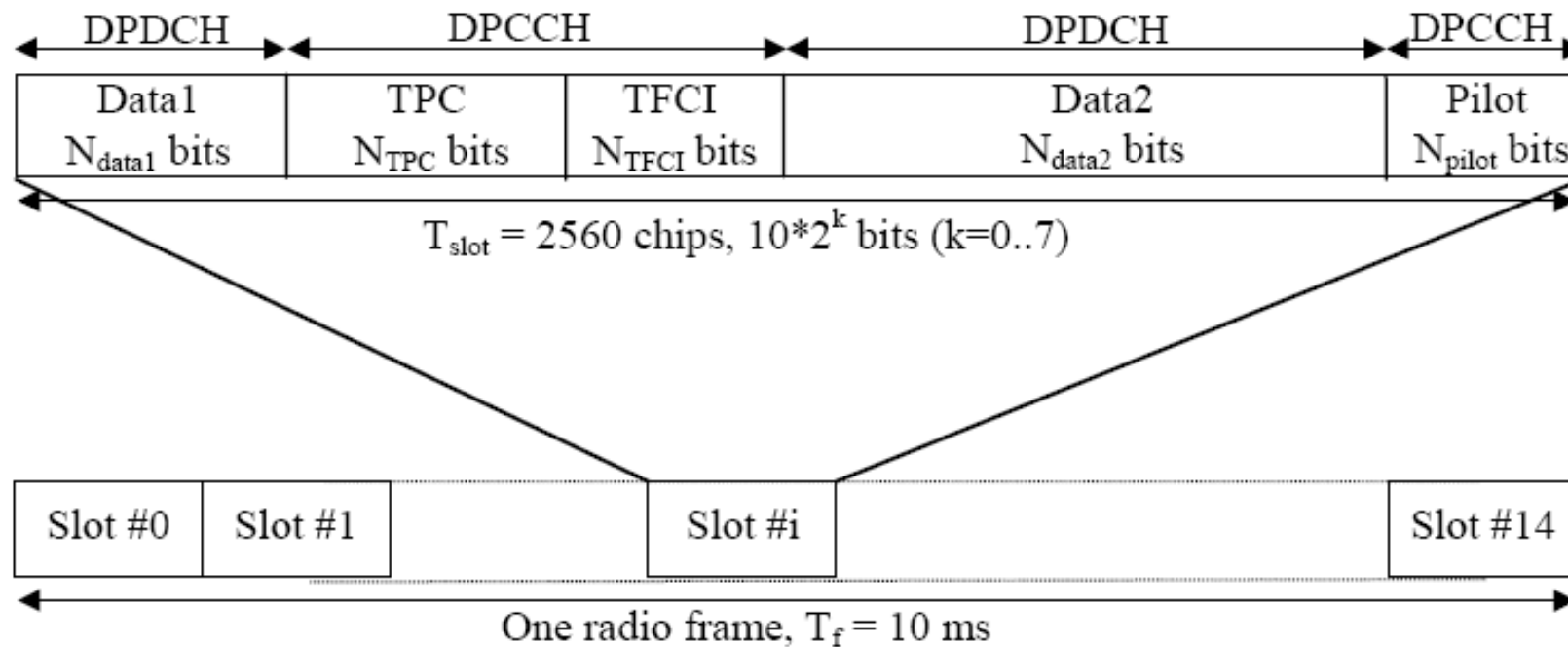

Channel structure - DL

Slot Format #i	Channel Bit Rate (kbps)	Channel Symbol Rate (ksps)	SF	Bits/Slot	DPDCH Bits/Slot		DPCCH Bits/Slot			Transmitted slots per radio frame N_{Tr}
					N_{Data1}	N_{Data2}	N_{TPC}	N_{TFCI}	N_{Pilot}	
0	15	7.5	512	10	0	4	2	0	4	15
0A	15	7.5	512	10	0	4	2	0	4	8-14
0B	30	15	256	20	0	8	4	0	8	8-14
1	15	7.5	512	10	0	2	2	2	4	15

14B	960	480	8	640	112	464	16	16*	32	8-14
15	960	480	8	640	120	488	8	8*	16	15
15A	960	480	8	640	120	480	8	16*	16	8-14
15B	1920	960	4	1280	240	976	16	16*	32	8-14
16	1920	960	4	1280	248	1000	8	8*	16	15
16A	1920	960	4	1280	248	992	8	16*	16	8-14

Fyzická vrstva - DL

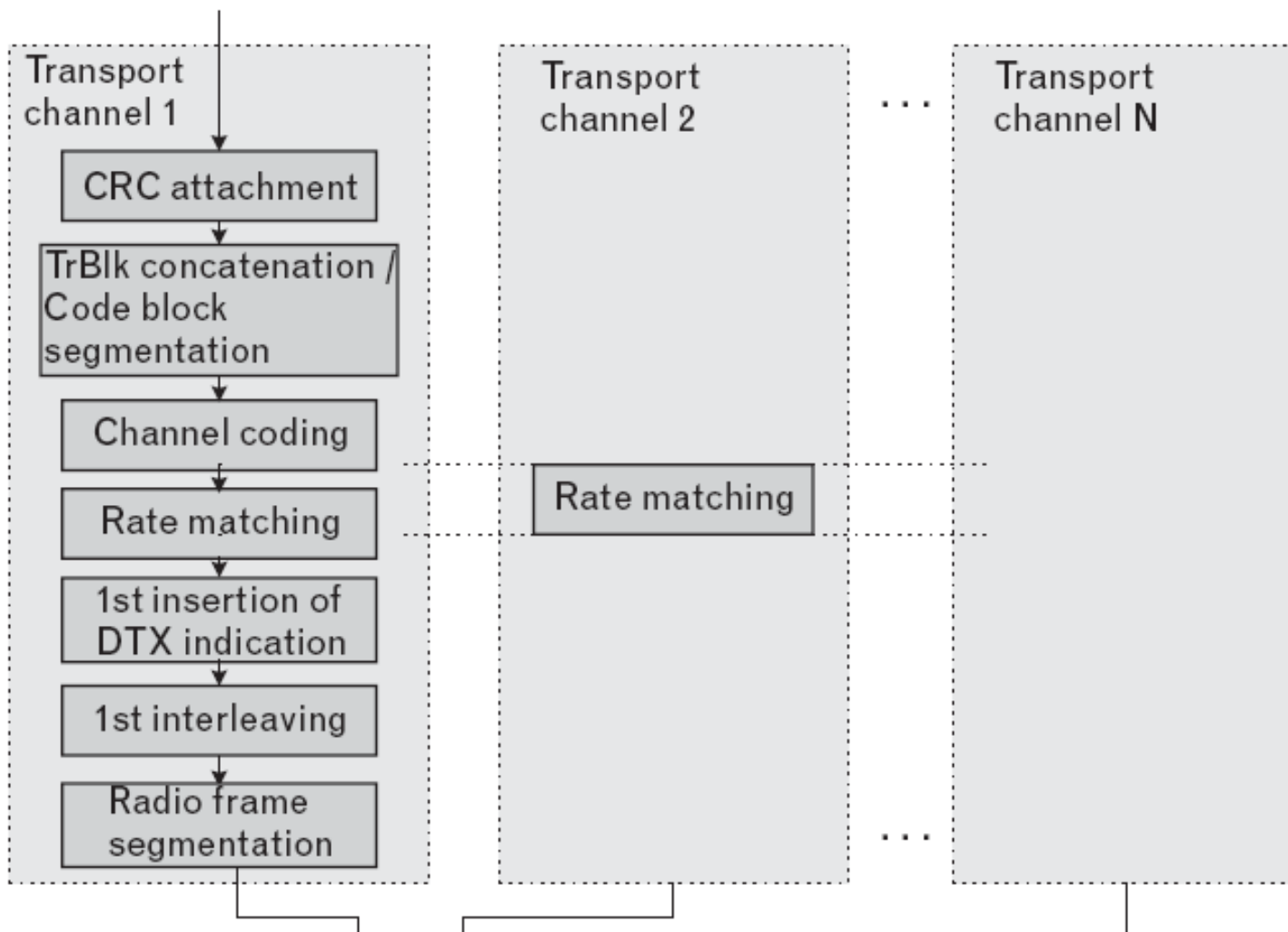

Channel Coding

Type of TrCH	Coding scheme	Coding rate
BCH	Convolutional coding	1/2
PCH		
RACH		
DCH, FACH	Turbo coding	1/3

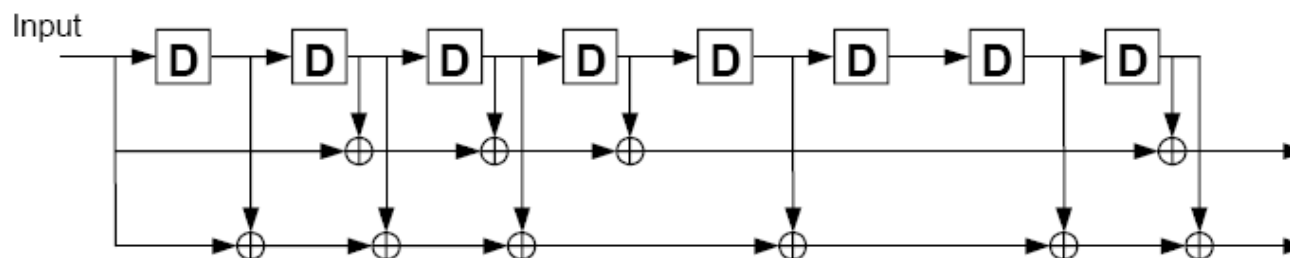

(a) Rate 1/2 convolutional coder

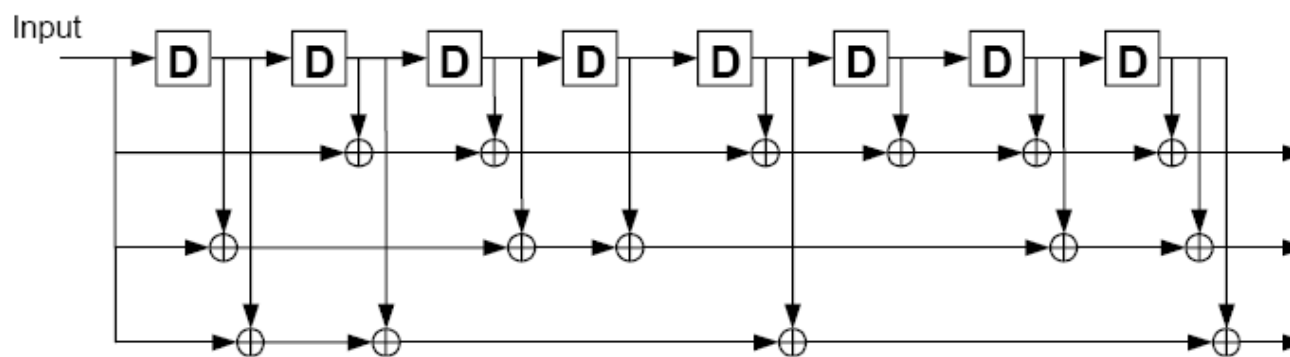

(b) Rate 1/3 convolutional coder

Fyzická vrstva - DL

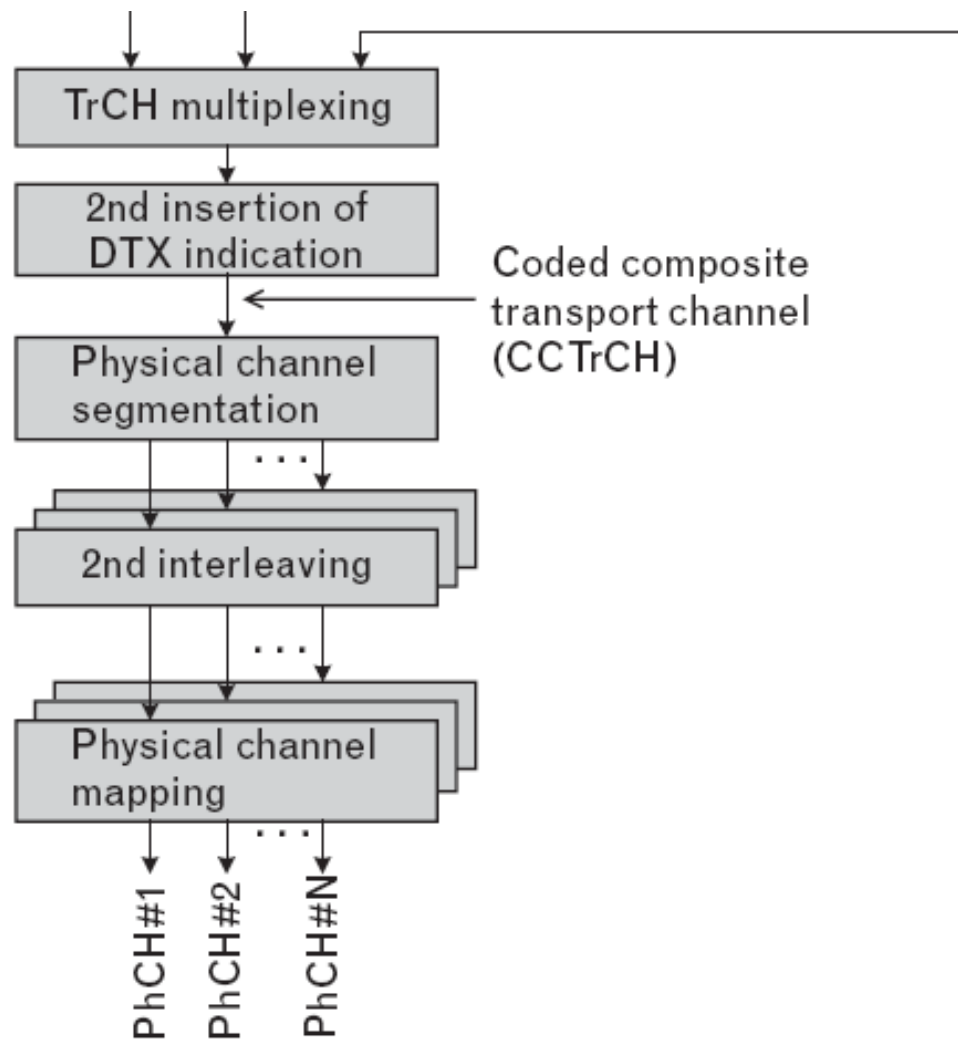

Spreading - UL

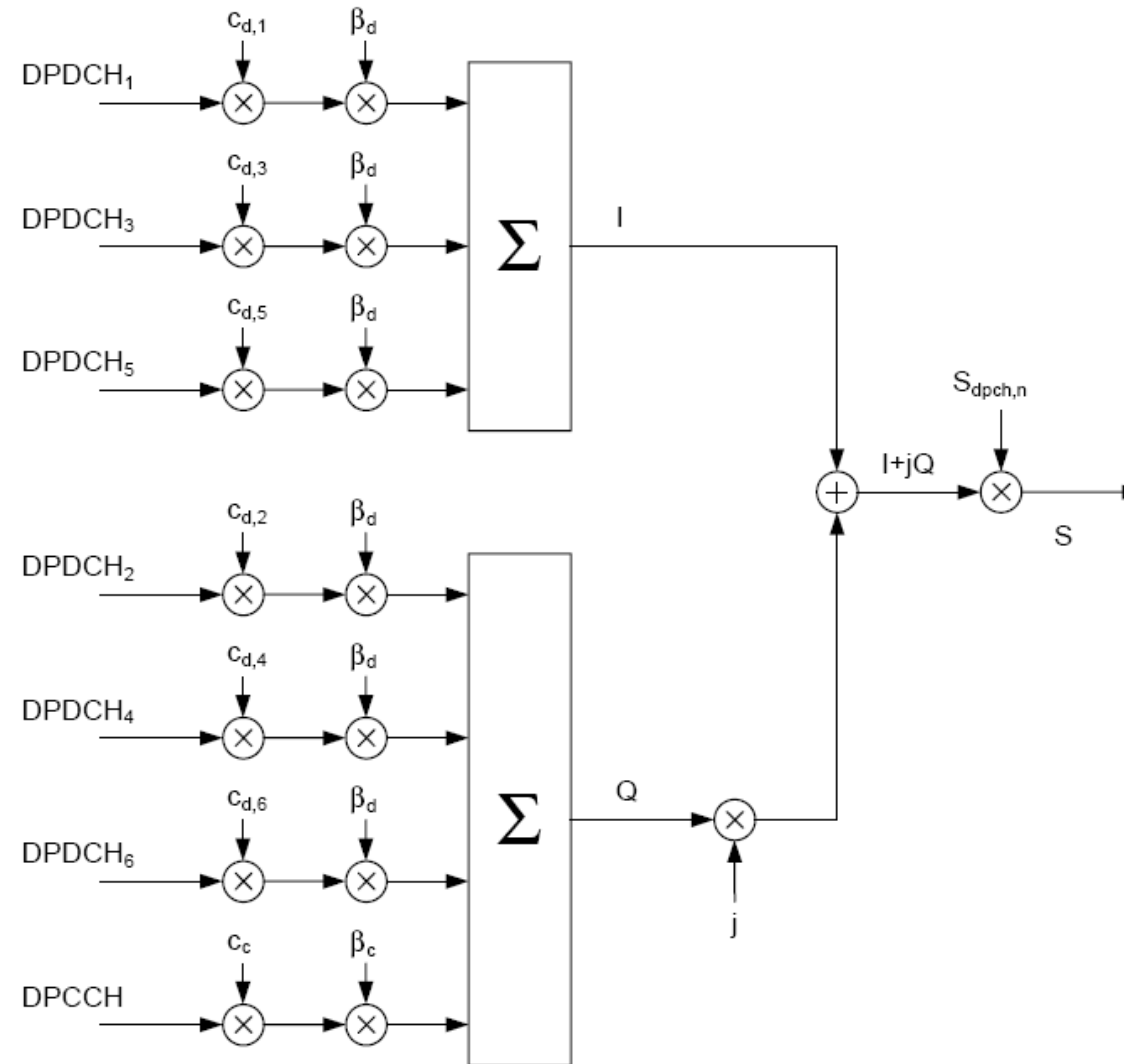

Modulation - UL

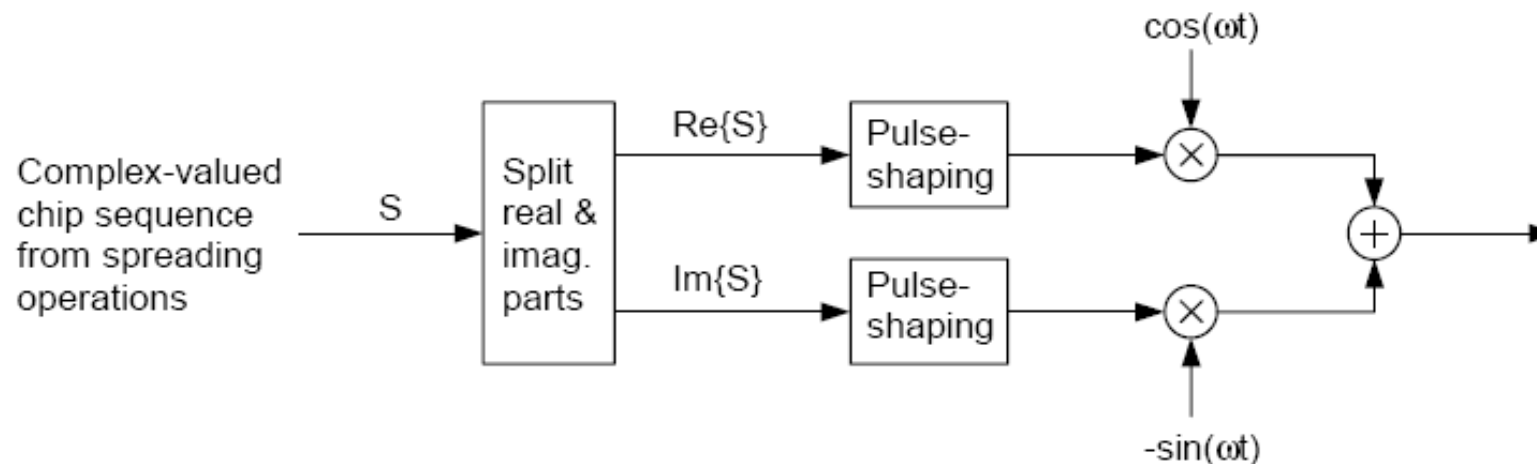

root-raised cosine (RRC) with roll-off $\alpha = 0.22$

$$RC_0(t) = \frac{\sin\left(\pi \frac{t}{T_C} (1 - \alpha)\right) + 4\alpha \frac{t}{T_C} \cos\left(\pi \frac{t}{T_C} (1 + \alpha)\right)}{\pi \frac{t}{T_C} \left(1 - \left(4\alpha \frac{t}{T_C}\right)^2\right)}$$

RRCF impulse response

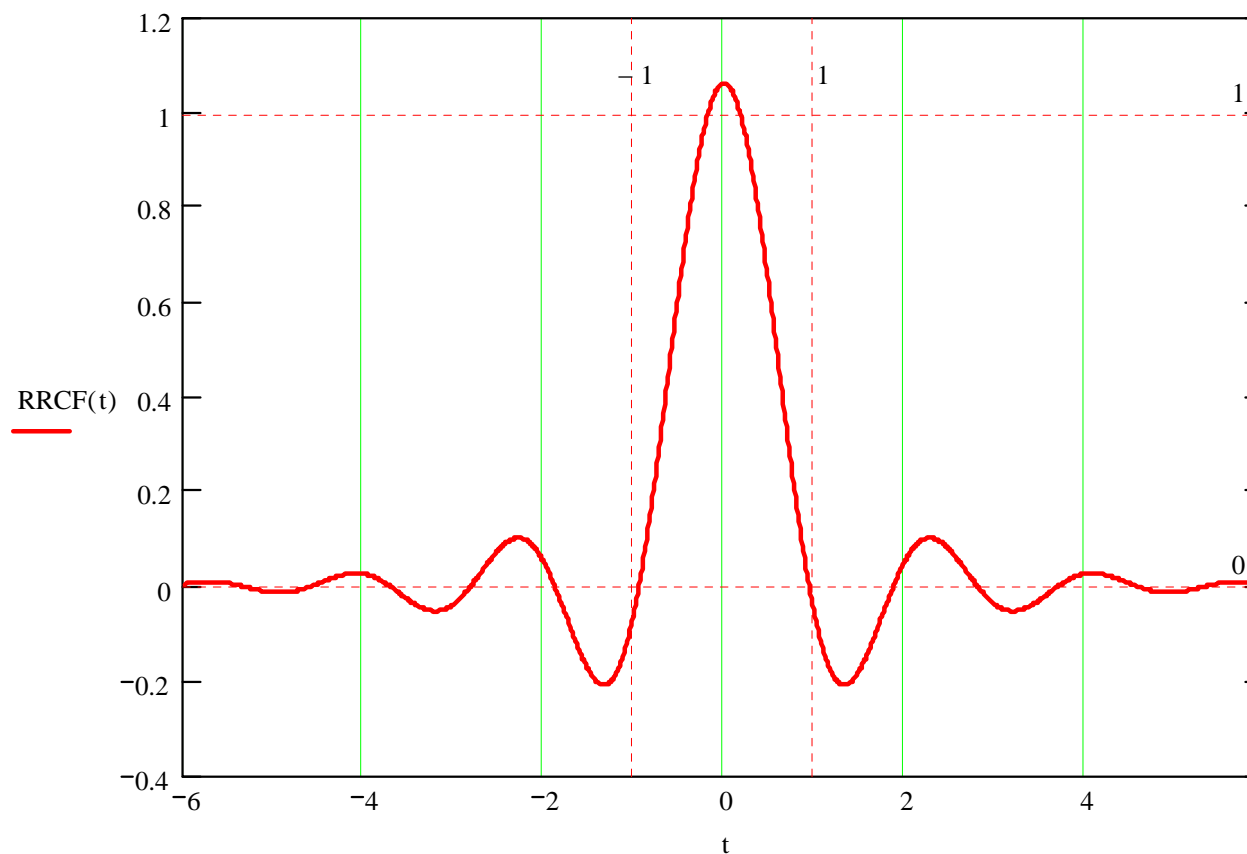

normalized $T_c = 1$ ($T_c = 26,042 \mu s$)

Spreading - DL

Any downlink physical channel except SCH

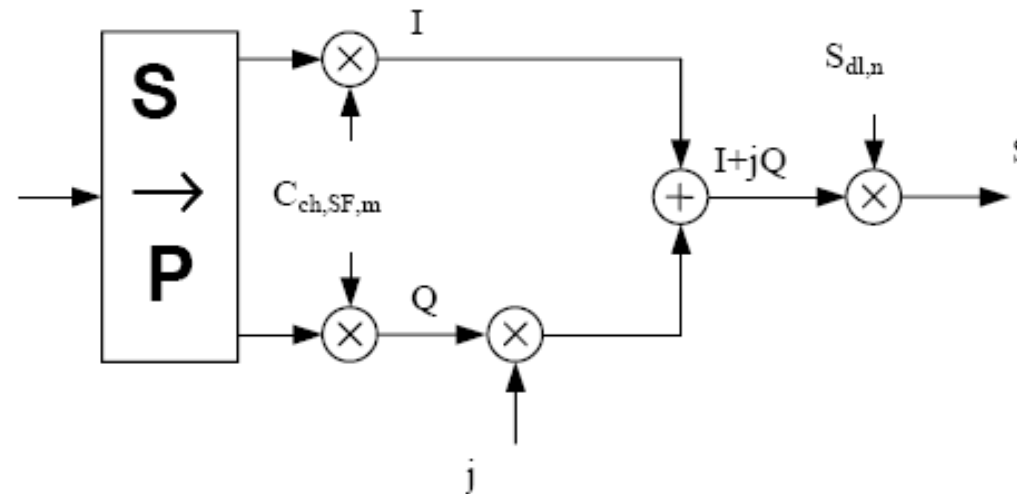

Modulation - DL

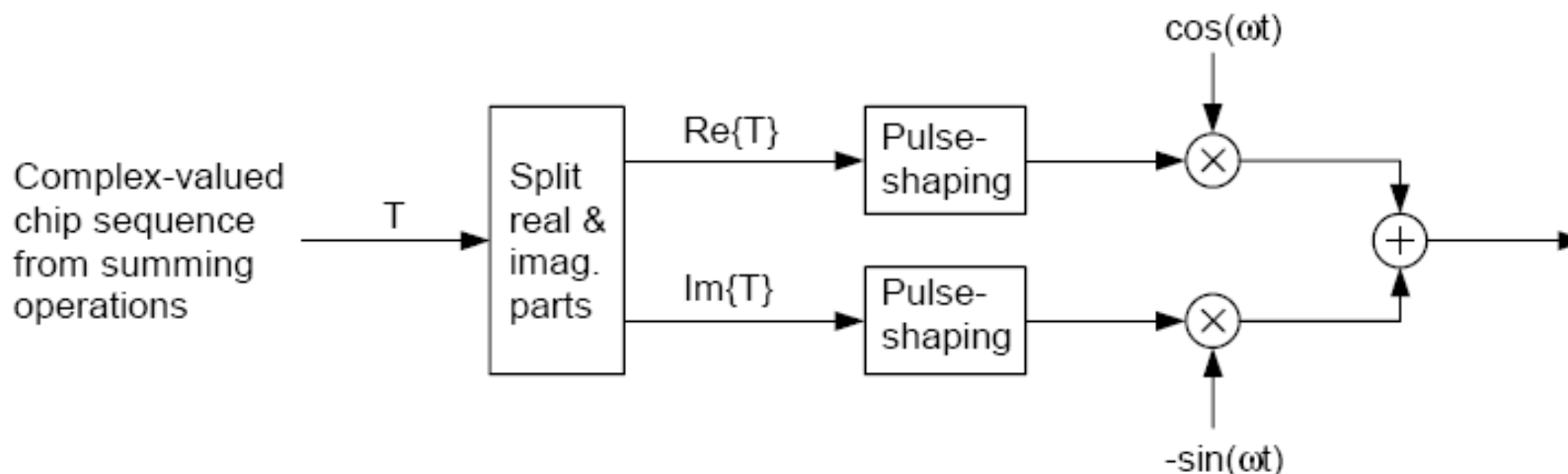

root-raised cosine (RRC) with roll-off $\alpha = 0.22$

$$RC_0(t) = \frac{\sin\left(\pi \frac{t}{T_C} (1 - \alpha)\right) + 4\alpha \frac{t}{T_C} \cos\left(\pi \frac{t}{T_C} (1 + \alpha)\right)}{\pi \frac{t}{T_C} \left(1 - \left(4\alpha \frac{t}{T_C}\right)^2\right)}$$

Codes

	Synchronisation Codes	Channelisation Codes	Scrambling Codes, UL	Scrambling Codes, DL
Type	Gold Codes Primary Synchronization Codes (PSC) and Secondary Synchronization Codes (SSC)	Orthogonal Variable Spreading Factor (OVSF) codes sometimes called Walsh Codes	Complex-Valued Gold Code Segments (long) or Complex-Valued S(2) Codes (short) Pseudo Noise (PN) codes	Complex-Valued Gold Code Segments Pseudo Noise (PN) codes
Length	256 chips	4-512 chips	38400 chips / 256 chips	38400 chips
Duration	66.67 μs	1.04 μs - 133.34 μs	10 ms / 66.67 μs	10 ms
Number of codes	1 primary code / 16 secondary codes	= spreading factor 4 ... 256 UL, 4 ... 512 DL	16,777,216	512 primary / 15 secondary for each primary code
Spreading	No, does not change bandwidth	Yes, increases bandwidth	No, does not change bandwidth	No, does not change bandwidth
Usage	To enable terminals to locate and synchronise to the cells' main control channels	UL: to separate physical data and control data from same terminal DL: to separate connection to different terminals in a same cell	Separation of terminal	Separation of sectors

$$2^{18} - 1 = 262,143$$

OVSF

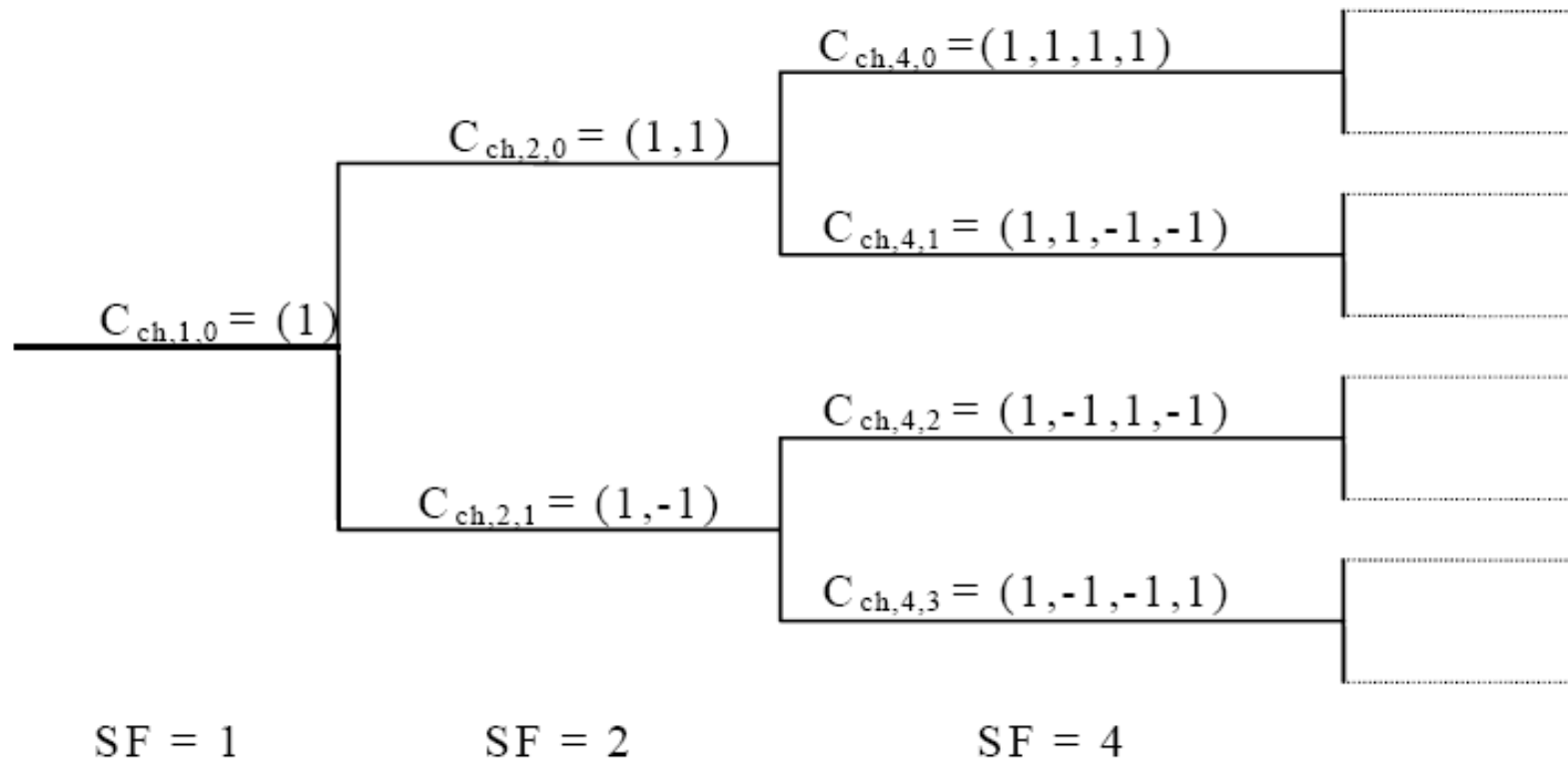

Scrambling codes - UL

(long code)

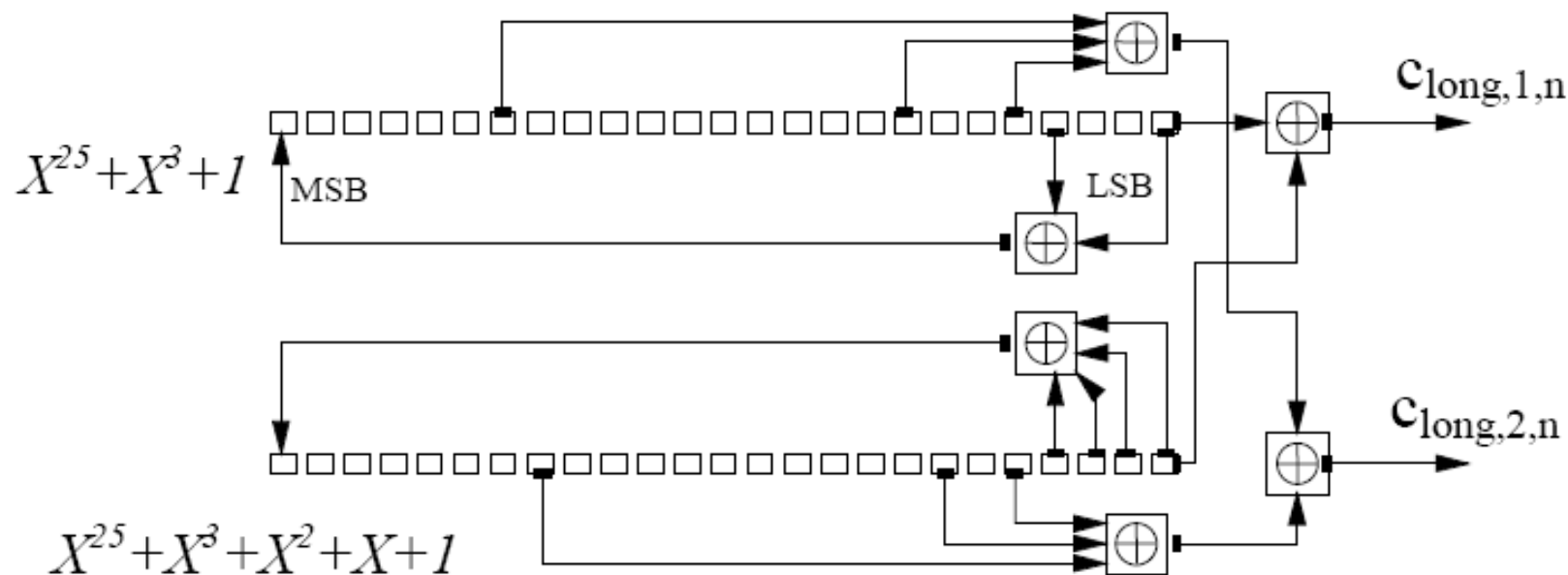

$$C_{long,n}(i) = c_{long,1,n}(i) \left(1 + j(-1)^i c_{long,2,n}(2 \lfloor i/2 \rfloor) \right)$$

Scrambling - DL

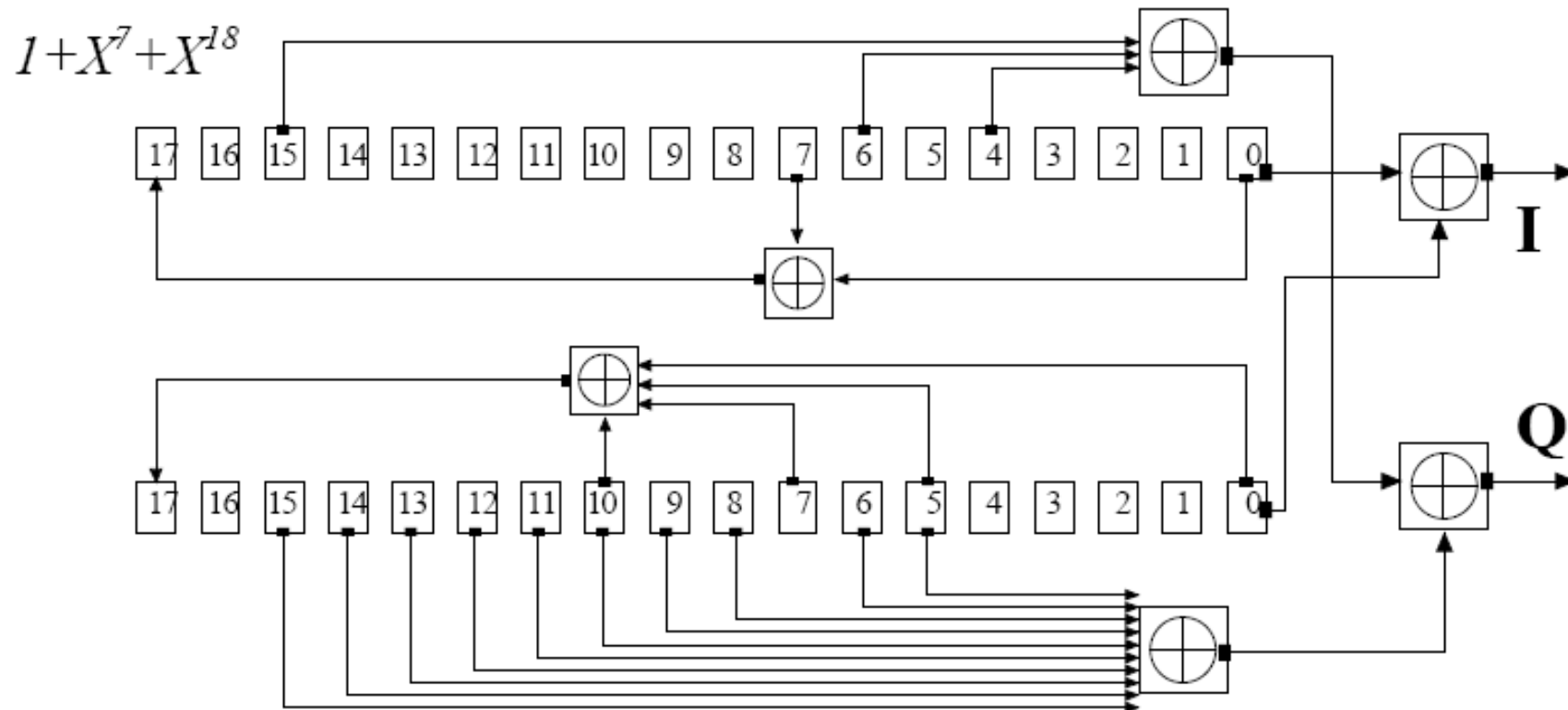

$$1 + X^5 + X^7 + X^{10} + X^{18}$$

Spreading & scrambling

$$s_j^{DS}(t) = \sum_{i=-\infty}^{+\infty} \sum_{k=0}^{K^{DS}-1} a_j(i) b_j(k) c_j(k + iK^{DS}) p_c(t - kT_c - iT_s)$$

Received signal

$$r^{DS}(t) = \sum_{j=1}^J r_j^{DS}(t) + n(t)$$

$$r_j^{DS}(t) = \int_{-\infty}^{+\infty} s_j^{DS}(t - \tau) h_j(\tau; t) d\tau = \sum_{l=1}^J \beta_{l,j}(t) s_j^{DS}(t - \tau_l)$$

Detection

$$\begin{aligned}
 D_{j'}^{DS}(i) &= D_{j'}^{DS}(t = iT_s) \\
 &= \sum_{l=1}^I \beta_{l,j'}^*(iT_s) \frac{1}{T_s} \int_{iT_s + \tau_l}^{(i+1)T_s + \tau_l} b_{j'}^*(k) c_{j'}^*(k + iK^{DS}) \\
 &\quad \times p_c(t - kT_c - iT_s - \tau_l) r^{DS}(t) dt
 \end{aligned}$$

I = number of fingers of RAKE receiver

Measurements

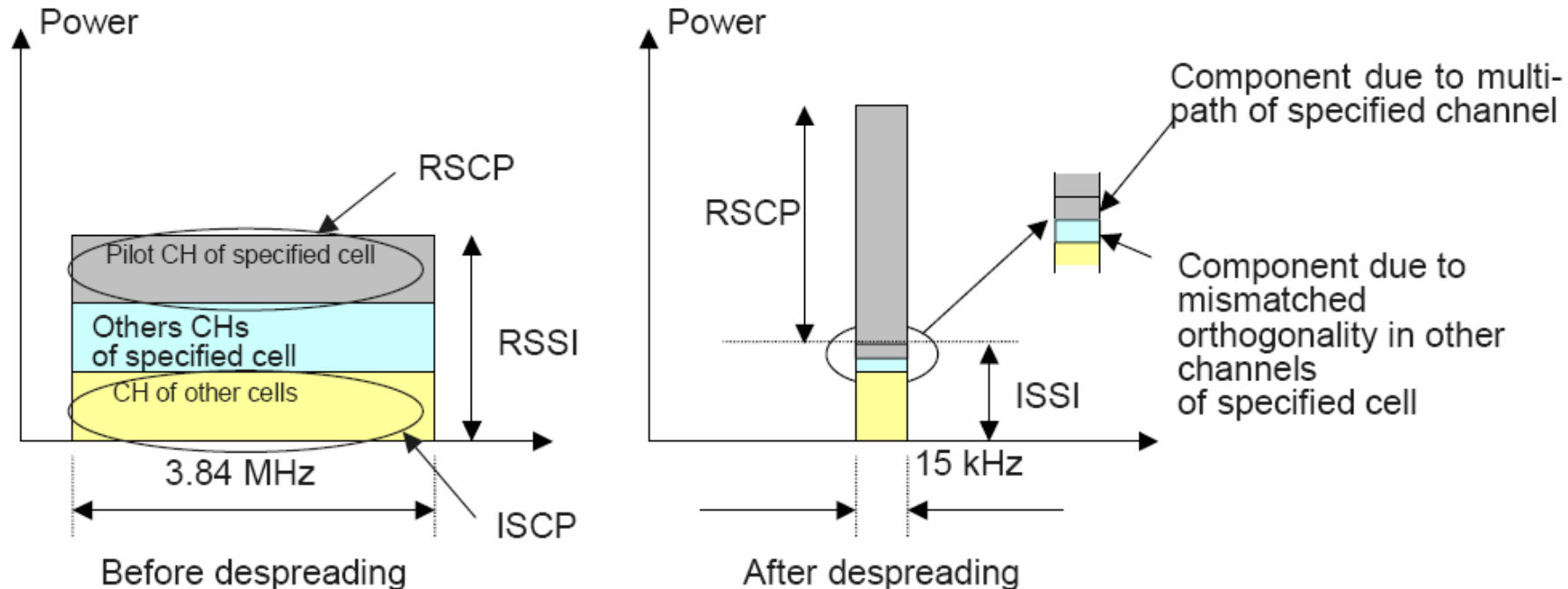

- RSSI:** Receive signal strength indicator (total receive signal power within 3.84 MHz band)
- RSCP:** Receive signal code power (of Pilot channel CPICH)
- ISCP:** Interference signal code power
- ISSI:** Interference signal code power after despreading ($ISSI = ISCP/SF$)
- SF:** Spreading factor (of CPICH = 256)
- SIR:** Signal to interference ratio $SIR = RSCP/ISSI = (RSCP/ISCP) \times SF$
- E_c/N_o :** $E_c/N_o = RSCP/RSSI$

Limiting factors

- Downlink is power limited

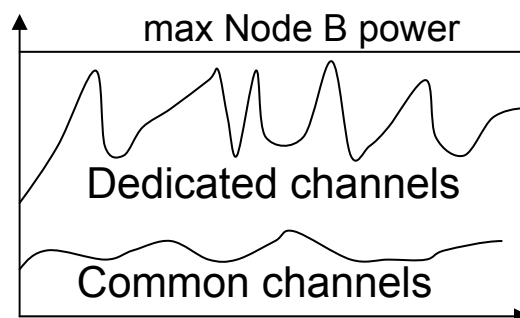

- Uplink is interference limited

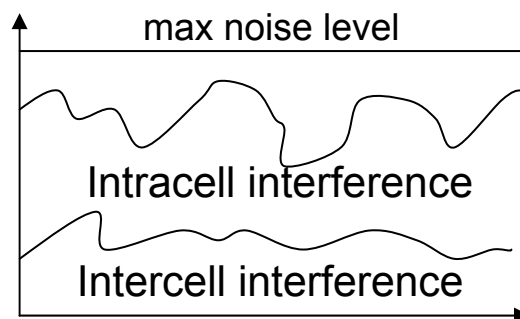

Power dynamics



Ref 54.6 dBm Att 40 dB RBW 10 MHz
 VBW 10 MHz SWT 1 s 100 ms

P_{nom}

P_{CCH}

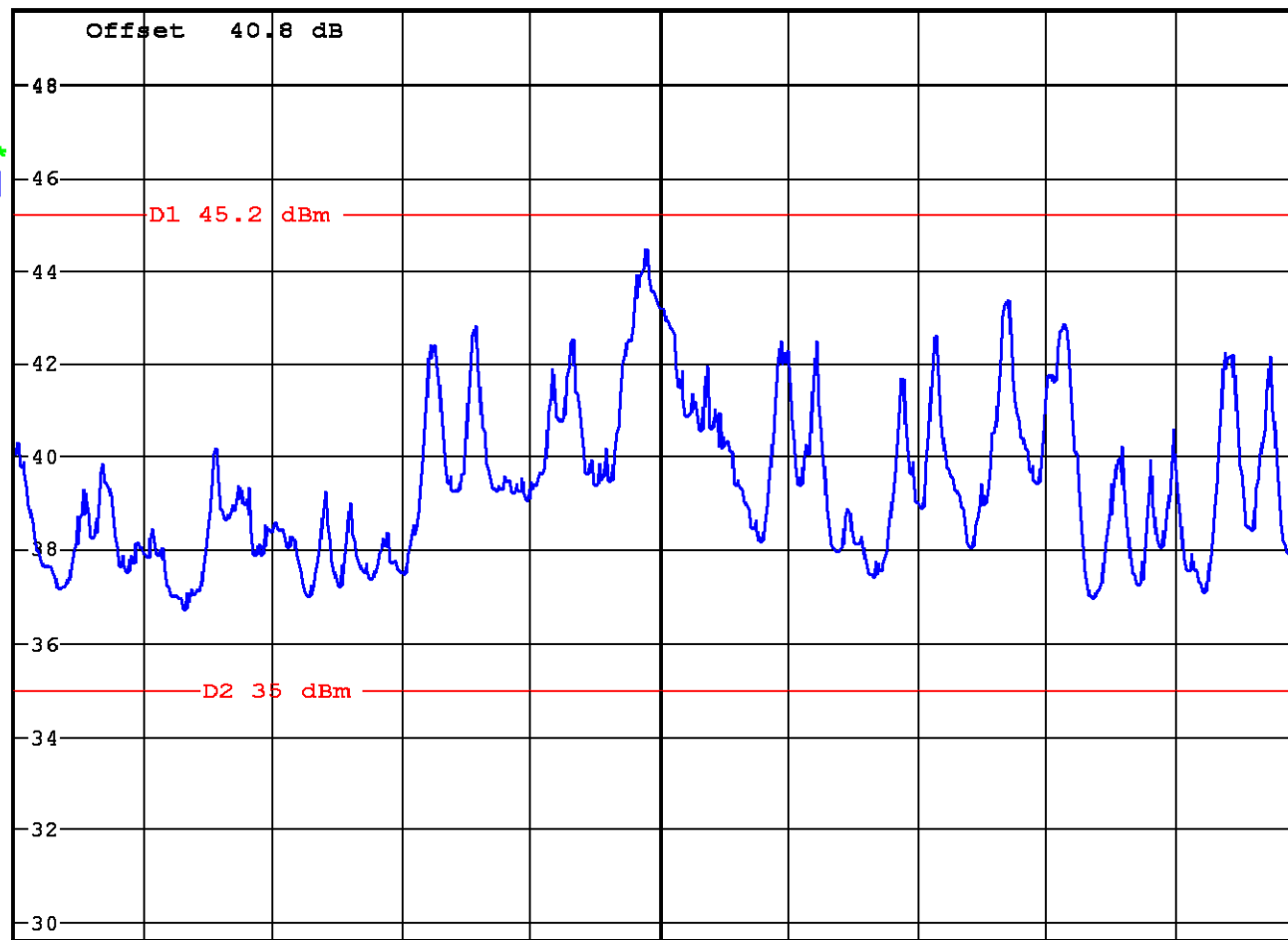

Center 2.1624 GHz 100 ms/



Services & RABs

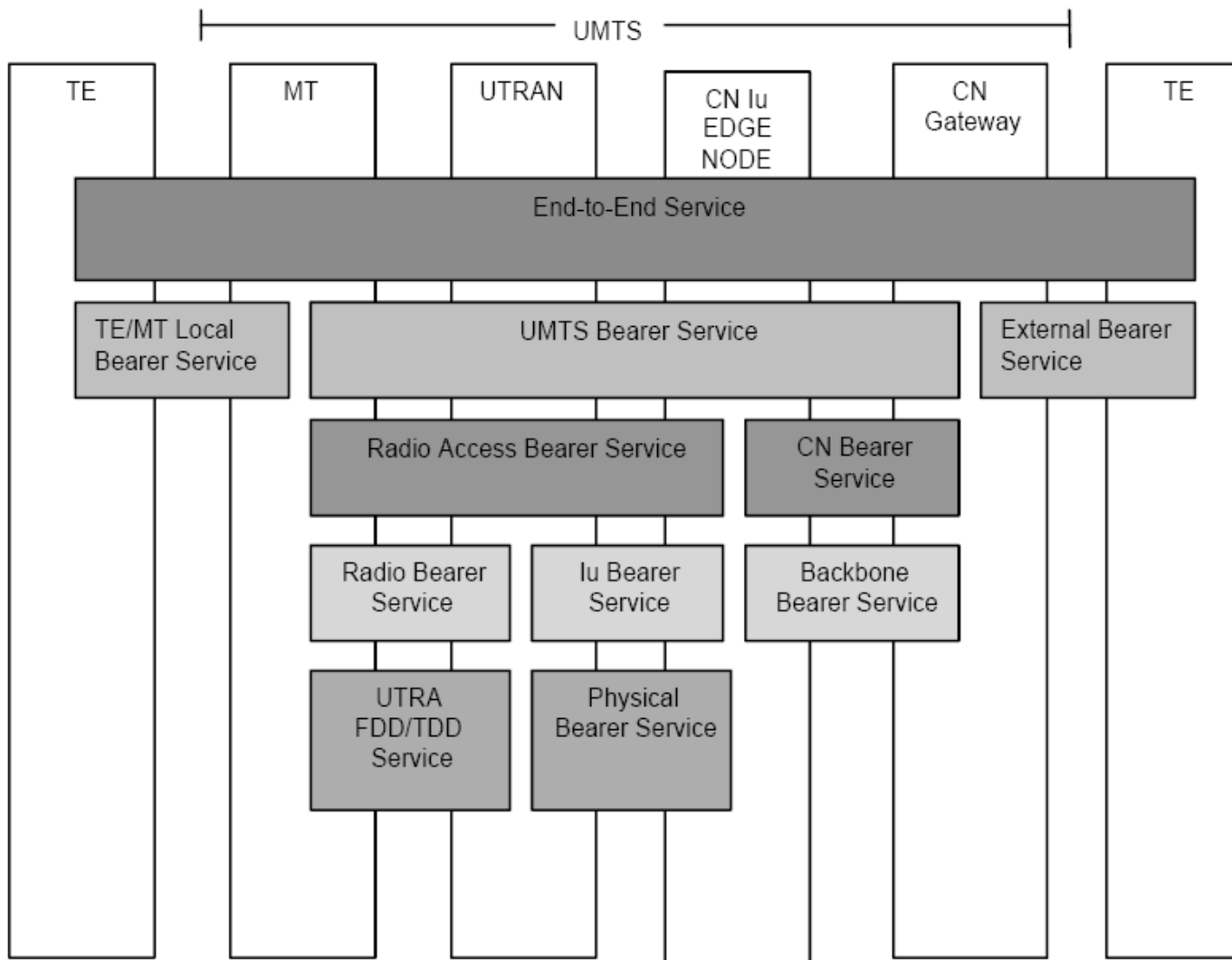

Services & RABs

- New service: Video Call

RAB type	Rate [kbps]
CS voice	12,2
CS video call	64
CS Streaming	57
PS Best Effort	64/128/384

